

Approved for tabling in the House.

~~RWA~~ SNA
14/4/2022

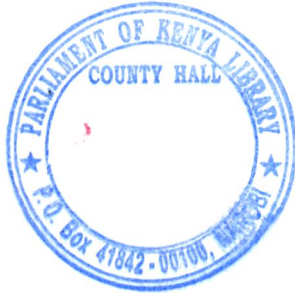

**REPUBLIC OF KENYA
THE NATIONAL ASSEMBLY**

TWELFTH PARLIAMENT – SIXTH SESSION

DEPARTMENTAL COMMITTEE ON DEFENCE & FOREIGN RELATIONS

**REPORT ON THE CONSIDERATION OF THE MILITARY VETERANS BILL
(NATIONAL ASSEMBLY BILL NO. 4 OF 2022)**

Published by:-

**The Directorate of Departmental Committees
Clerk's Chambers
Parliament Buildings
NAIROBI**

 THE NATIONAL ASSEMBLY PAPERS LAID		14/04/2022
DATE: 14 APR 2022		APRIL, 2022
		DAY: THURS
TABLED BY:	HON. RICHARD TONGI, M.P.	
CLERK AT THE TABLE:	CHAIR, DEFENCE CHRISTINE NDIRITU	

Table of Contents

PART Iiv

1.0 PREFACEiv

1.1 Establishment and Mandate of the Committeeiv

1.2 Committee Membershipv

1.3 Committee Secretariatvi

PART II1

2.0 OVERVIEW OF THE MILITARY VETERANS BILL, 20221

PART III5

4.0 PUBLIC PARTICIPATION/ STAKEHOLDER ENGAGEMENT5

PART IV7

5.0 COMMITTEE'S PROPOSED AMENDMENTS7

PART V8

6.0 COMMITTEE'S RECOMMENDATION8

CHAIRPERSON'S FOREWORD

This report contains the Committee's proceedings on the consideration of the Military Veterans Bill (National Assembly Bill No. 4 of 2022) that was read a First Time on Tuesday, 22nd February, 2022, and committed to the Departmental Committee on Defence & Foreign Relations pursuant to Standing Order 127.

The Military Veterans Bill, 2022 sponsored by Hon. Amos Kimunya, MP, Leader of the Majority Party, is a Government-sponsored Bill that seeks to establish a regulatory and institutional framework for the management of military veterans' affairs; for the provision of benefits to military veterans and military veterans' dependants; to establish the Dependants' Education Fund; to establish the Defence Forces Retirement Home.

The Committee called for memoranda from the public pursuant to Article 118(1)(b) of the Constitution and Standing Order 127(3), and received responses from four stakeholders. The Committee further held a meeting with the chief practitioner and consumer of the Bill, the Ministry of Defence, on 1st April, 2022.

The stakeholders proposed certain amendments that have been exhaustively addressed in Part III of this report, with the Committee's final decision reflected therein and in the attached schedule.

On behalf of the Departmental Committee on Defence and Foreign Relations and pursuant to provisions of Standing Order 199 (6), it is my pleasant privilege and honour to present to this House the Report of the Departmental Committee on Defence and Foreign Relations on the Military Veterans Bill, 2022. The Committee is grateful to the offices of the Speaker and Clerk of the National Assembly for the logistical and technical support accorded to it during its sittings. The Committee further wishes to thank all stakeholders who submitted their comments on the Bill. Finally, I wish to express my appreciation to the Honourable Members of the Committee and the Committee Secretariat who made useful contributions towards the preparation and production of this report.

It is my pleasure to report that the Committee has considered the Military Veterans Bill, 2022 and has the honour to report back to the National Assembly with the recommendation that the Bill should be approved with amendments.

Hon. Richard Nyagaka Tongi, MP

Chairperson, Departmental Committee on Defence and Foreign Relations

PART I

1.0 PREFACE

1.1 Establishment and Mandate of the Committee

1. The Departmental Committee on Defence and Foreign Relations is established under Standing Order No. 216. Its mandate pursuant to SO 216 (5) with the following terms of reference;
 - i) investigate, inquire into and report on all matters relating to the mandate, management, activities, administration, operations and estimates of the assigned Ministries and Departments;*
 - ii) study the programme and policy objectives of the Ministries and Departments and the effectiveness of the implementation;*
 - iii) study and review all legislation after First Reading subject to the exemptions under Standing Order 101 A (4);*
 - iv) study and review all legislation referred to it;***
 - v) study, assess and analyze the relative success of the Ministries and Departments as measured by the results obtained as compared with its stated objectives;*
 - vi) investigate and inquire into all matters relating to the assigned Ministries and Departments as they may deem necessary, and as may be referred to them by the House or a Minister; and*
 - vii) make reports and recommendations to the House as often as possible, including recommendations of proposed legislation.*
2. The Committee is mandated to consider the following subjects:
 - i) Defence
 - ii) intelligence,
 - iii) foreign relations
 - iv) diplomatic and consular services,
 - v) international boundaries,
 - vi) international relations,
 - vii) agreements,
 - viii) treaties and
 - ix) Conventions.
3. In executing its mandate, the Committee oversees the following government Ministries, departments and or agencies, namely:
 - i) Ministry of Defence
 - ii) Ministry of Foreign Affairs
 - iii) Ministry of East African Community & Regional Development
 - iv) The National Intelligence Service

1.2 Committee Membership

4. The Committee Membership is as follows:

The Hon. Richard Tongi, MP (Chairperson)
MP for Nyaribari Chache Constituency

Jubilee Party

The Hon. Memusi Ole Kanchory, MP (Vice Chairperson)
MP for Kajiado Central Constituency

Jubilee Party

The Hon. Yusuf Hassan Abdi, MP
MP for Kamukunji Constituency

Jubilee Party

The Hon. Charles Kilonzo, MP
MP for Yatta Constituency

Independent

The Hon. Stephen Mule, MP
MP for Matungulu Constituency

WDM-K Party

The Hon. Dido Ali Raso, MP
MP for Saku Constituency

Jubilee Party

The Hon. Maoka Maore, MP
MP for Igembe North

Jubilee Party

The Hon. Irene Kasalu, MP
MP for Kitui County

WDM-K Party

The Hon. Gideon Konchella, MP
MP for Kilgoris Constituency

Jubilee Party

The Hon. (Dr.) Adan Keynan
Wehliye, CBS, MP
MP for Eldas Constituency

ODM Party

The Hon. Martha Wangari, MP
MP for Gilgil Constituency

Jubilee Party

The Hon. Major (Rtd.) Bashir Sheikh
Abdullah, MP

MP for Mandera North Constituency

Jubilee Party

The Hon. (Dr.) Lilian Gogo, MP
MP for Rangwe Constituency

ODM Party

The Hon. Zachary Thuku, MP
MP for Kinangop Constituency

Jubilee Party

The Hon. Moses Nguchine Kirima,
MP

MP for Central Imenti Constituency

Jubilee Party

The Hon. Vincent K. Tuwei, MP
MP for Mosop Constituency

Jubilee Party

The Hon. Ernest Ogesi Kivai, MP
MP for Vihiga Constituency

ANC Party

The Hon. Caleb Amisi, MP
MP for Saboti Constituency

ODM Party

The Hon. Asha Hussein Mohamed,
MP

MP for Mombasa County

ODM Party

1.3 Committee Secretariat

5. The Committee is facilitated by the following members of the secretariat.

Mr. Daniel Mutunga
Principal Clerk Assistant I
Lead Clerk

Mr. Abdiaziz Shobay
Clerk Assistant II

Mr. Edison Odhiambo
Fiscal Analyst

Mr. John Ng'ang'a
Audio Officer

Mr. Said Wako
Sergeant At-Arm

Ms. Mercy Wanyonyi/ Mr. Salem
Lorot/ Brigitta Mati
Legal Counsels

Ms. Deborah Mupusi
Media Relations Officer

Mr. Edwin Machuki
Fiscal Analyst

PART II

2.0 OVERVIEW OF THE MILITARY VETERANS BILL, 2022

6. The Military Veterans Bill (National Assembly Bills No. 4 of 2022), seeks to establish a regulatory and institutional framework for the management of military veterans' affairs; for the provision of benefits to military veterans and military veterans' dependants; to establish the Dependants' Education Fund; to establish the Defence Forces Retirement Home.
7. It is to be noted that the Kenya Defence Forces Act (No. 25 of 2012) provides for the functions, organization and administration of the Kenya Defence Forces pursuant to Articles 232 and 239(6) of the Constitution; gives effect to Article 241 and other relevant Articles of the Constitution, provides for disciplinary matters, among other things. However, it does not address what the Bill seeks to achieve.
8. The Bill contains 23 clauses.

B. OVERVIEW OF THE BILL

9. The Bill contains six Parts. These are:

Part 1- Preliminary

Part 2- Military Veterans' Benefits

Part 3- Administration

Part 4- Dependants' Education Fund

Part 5- Defence Forces Retirement Home

Part 6- Regulations

10. Clause 1 of the Bill contains the short title.
11. Clause 2 of the Bill contains definitions of key terms used in the Bill.
12. Clause 3 of the Bill provides for the principal objects of the Act including the management of military veterans' affairs; the provision of benefits to military veterans and military veterans' dependants; the establishment of the Dependants' Education Fund; and the establishment of the Defence Forces Retirement Home.
13. Clause 4 of the Bill provides for the guiding principles of the Act including principles relating to military veterans; policies relating to military veterans and principles for the management of funds relating to military veterans.
14. Clause 5 of the Bill provides that the benefits conferred under the Act shall not be conferred on a person merely because that person is a military veteran as defined under the Act.
15. Clause 6 of the Bill provides for the meaning of "military veteran", that is, a person who has retired from military service and who had served in the Kenya Defence Forces, the Kenya Armed Forces after 1963, or in the Kings African Rifles before 1963; has completed service in the Armed Forces or Kenya Defence Forces, receives a military pension and who was not dishonourably discharged from military service.
16. Clause 6 also provides that a person who was discharged or retired from the Armed Forces or Kenya Defence Forces on medical grounds shall, whether or not that person receives a pension, be regarded as a military veteran except if the person suffers from a physical or mental disability that was self-inflicted or occasioned by the use of narcotic drugs or psychotropic substances.

17. Clause 7 of the Bill provides for the benefits conferred under the Act to military veterans and military veterans' dependants; the role of the Defence Council in the provision of those benefits; the obligations of Government ministries, the departments and agencies; and the role of the Principal Secretary in the ministry responsible for military veterans.
18. Under clause 7, the benefits that may be conferred on a military veteran are:
- Counselling and treatment for post-traumatic stress or related conditions
 - Physical rehabilitation for any condition arising out of military service
 - Honouring and memorializing fallen military veterans
 - Education, training and skills development
 - Facilitation or advice on employment placement
 - Facilitation or advice on business opportunities.
19. Under clause 7, the following benefits may be conferred on a military veterans' dependants:
- Counselling and treatment for post-traumatic stress or related conditions
 - Facilitation or assistance in education placement for children of military veterans
 - Facilitation or advice on employment placement
 - Facilitation or advice on business opportunities
20. Clause 8 of the Bill provides for the powers of the Defence Council under the Act. It provides that the Defence Council shall have the following powers:
- Develop a policy on military veterans
 - Consider proposals by the Cabinet Secretary, the Chief of Defence Forces or the Director regarding the policy on military veterans, funding and budgeting in connection with military veterans' affairs
 - Commission research or studies on any issue affecting military veterans
 - Promote the implementation of programmes relating to military veterans' affairs under the Act
 - Take such steps as may be necessary for the achievement of the objects of the Act
21. Clause 9 of the Bill establishes the office of the Director of Military Veterans and places it under the supervision of the Chief of Defence Forces. It also provides for the revocation of the appointment of the Director or the Director's redeployment by the Defence Council.
22. Clause 10 of the Bill provides for the functions of the Director.
23. Clause 11 of the Bill provides for the establishment of the Advisory Committee on Military Veterans, its membership and the appointment of its members. It provides that the Advisory Committee shall comprise:
- A chairperson appointed by the President on the recommendation of the Defence Council
 - Six other members appointed by the Defence Council
24. Clause 12 of the Bill provides for the qualifications of the members of the Advisory Committee. It provides that a person shall be qualified to be appointed as the chairperson or member of the Advisory Committee if that person—
- In the case of the chairperson, is a retired general officer of the Armed Forces or Kenya Defence Forces
 - In the case of a member appointed under subsection 11(2) (b), is a military veteran

- Meets the requirements of Chapter Six of the Constitution
 - Has not acted in a manner that is prejudicial to national security since the end of his or her military service
25. Clause 13 of the Bill provides for the procedure for the filing of vacancies in the Advisory Committee.
 26. Clause 14 of the Bill provides for the tenure of the members of the Advisory Committee.
 27. Clause 15 of the Bill provides for the determination of the remuneration and allowances of the members of the Advisory Committee.
 28. Clause 16 of the Bill provides for the procedure for the removal from office of a member of the Advisory Committee.
 29. Clause 17 of the Bill provides for the manner in which a vacancy may arise in the Advisory Committee including notice periods in case a member wishes to resign from office.
 30. Clause 18 of the Bill provides for the functions of the Advisory Committee.
 31. Clause 19 of the Bill provides for the reports of the Advisory Committee to the Defence Council.
 32. Clause 20 of the Bill provides for the procedure for the convening of the meetings of the Advisory Committee and the obligation to declare conflicts of interest regarding any matter being considered by the Advisory Committee.
 33. Clause 21 of the Bill provides for the establishment of the Dependants' Education Fund to provide scholarships for the children of members of the Kenya Defence Forces, military veterans or deceased service members or deceased veterans. It provides that the Defence Council shall establish a fund to be known as the Dependants' Education Fund. It further provides that the Defence Council shall prescribe regulations for the administration of the Fund including the procedure for processing applications for scholarships from the Fund.
 34. Clause 22 of the Bill provides for the establishment of the Kenya Defence Forces Retirement Home to provide residential and other services to military veterans. It further provides that the Defence Council shall prescribe Regulations for the achievement of the objects of the section and provide for—
 - persons who shall be eligible to reside in the Defence Forces Retirement Home
 - the services to be provided in the Defence Forces Retirement Home
 - contributions to be made by members of the Kenya Defence Forces with respect to the Defence Forces Retirement Home
 - any other relevant matter relating to the Defence Forces Retirement Home
 35. Clause 23 of the Bill provides for the making of Regulations by the Cabinet Secretary for the better carrying out of the provisions of the Act. The regulations will provide for:
 - The manner of accessing any benefit provided under the Act
 - Any matter required or permitted to be prescribed by or in accordance with the Act

B. PUBLIC PARTICIPATION

36. The Committee is required, pursuant to Article 118(1)(b) of the Constitution and Standing Order 127(3), to facilitate public participation on the Bill through an appropriate mechanism including-
- (a) Inviting submission of memoranda;
 - (b) Holding public hearings;
 - (c) Consulting relevant stakeholders in the sector;
 - (d) Consulting experts on technical subjects.
37. The requirement for the Committee to conduct public participation on the Bill is a constitutional imperative flowing from Article 118 of the Constitution which provides that Parliament shall-
- (a) conduct its business in an open manner, and its sittings and those of its committees shall be open to the public; and
 - (b) facilitate public participation and involvement in the legislative and other business of Parliament and its committees.
38. It is important to note that Standing Order 127(4) requires the Chairperson of the Departmental Committee to which a Bill is committed or a Member designated for that purpose by the Committee to present the Committee's report to the House to inform debate within twenty-one calendar days of such committal and upon such presentation, or if the Committee's report is not presented when it becomes due, the Bill shall be ordered to be read a Second Time on such day as the House Business Committee shall, in consultation with the Member or the Committee in charge of the Bill, appoint.

PART III

4.0 PUBLIC PARTICIPATION/ STAKEHOLDER ENGAGEMENT

39. Following call for memoranda from the public through the placement of advertisements in the print media on 24th February, 2022 requesting for comments from the public on the Bill.

40. The Committee received memoranda from the following stakeholders;

- i. Ministry of Defence
- ii. National Gender and Equality Commission
- iii. Mr. Ernest Kinyua Kamau through Lawyer, Miller & Co. Advocates
- iv. Ugunya/Ugunja Veteran Development Group
- v. Creative Industrial Arts Technologists Association of Kenya

41. The stakeholders made submissions as elaborated in the clauses below, with the Committee observations thereunder;

a) **Creative Industrial Arts Technologists Association**

42. The Creative Industrial Arts Technologists Association proposed for the initiation of technology and business development initiatives to form the specified field of technology acquired from retired members of the security forces.

43. The Committee observed that this is proposal that can be considered once the structures are instituted as it falls with the mandate of the Advisory Committee.

b) **Miller and Company advocates instructed by Capt (Rtd) Ernest Kinyua Kamau (20813)**

44. The Firm proposed the following:

THAT Section 11(d) and Section 9(e) of the proposed Bill are discriminative as they require one to have completed service to be eligible for the benefits under the Bill.

45. The Committee observed that this is in line with the guiding principles of honouring those who served and made sacrifices to protect the country. Completing service or at least attaining the 10 and 12 years in service for officers and service members respectively distinguishes those entitled to the benefit from those who quit service prematurely.

c) **National Gender and Equality Commission**

46. The Commission proposed the following:

(a) to define a military veteran as a person who served in the army, air force or navy and has not been dishonourably discharged. The Committee observed that the definition contained in the bill is all encompassing as the armed forces and the Kenya defence Forces is comprised of the three services;

(b) Composition to include representation as stipulated in the Mwongozo to include the parent ministry, department of social protection, faith-based organizations, an elderly veteran and a veteran with disabilities. The Committee observed the following on the above proposals-

- i) the faith element is likely to invite controversy;
- ii) representation among ranks is the established practice which should be maintained; and
- iii) the Department of Veteran Affairs is established under the Defence Council and is not a state corporation.

(c) Delete establishment of Veteran's Education fund as it does not meet the thresholds stipulated in the PFMA Act. The Committee observed the following—

- i) To operationalize the fund, the Act has enabled the Defence Council to make regulations to attain its objects; and
- ii) MDAs are to co-operate with Veterans affairs to realize attainment of the benefit which includes National Treasury promulgating regulations under the PFMA.

(d) Define a retirement home, consider establishing more than one centre for the retirees to access and include the provision on the source of funds. The Committee observed that this can be considered once the structures are duly established.

47. Following deliberations with the Ministry of Defence and taking into consideration memoranda from the various stakeholders, the Committee proposed the following amendments to the Bill with justifications in the following manner—

PART IV

COMMITTEE'S PROPOSED AMENDMENTS

48. LONG TITLE

THAT, the long title to the Bill be amended by deleting the words “to establish the Defence Forces Retirement Home”

49. CLAUSE 2

THAT, Clause 2 of the Bill be amended—

- (a) by deleting the definition of the term “ child” and substituting therefor the following new definition—

“Child” means a child of a Kenya Military Veteran under the age of eighteen years;”

- (b) by inserting the following new definition in its proper alphabetical sequence—

“private entity” means any person or private group, organization, proprietorship, partnership, trust, cooperative, association, corporation, or other commercial or non-profit entity duly established and/or registered under applicable laws in Kenya or in other jurisdictions that accept to co-operate and voluntarily fund any object and/or activity envisaged under this Act including an officer, employee, or agent thereof.

50. CLAUSE 3

THAT, Clause 3 of the Bill be amended by deleting paragraph (d).

51. CLAUSE 6

THAT, Clause 6 of the Bill be amended by—

- (a) deleting paragraph (a);
- (b) deleting paragraph (b); and
- (c) deleting paragraph (c).

52. CLAUSE 21

THAT, Clause 21 of the Bill be amended in sub clause (1) —

- (a) in paragraph (a), by deleting the words “ members of the Kenya Defence Forces and”;
- (b) in paragraph (b), by deleting the words “ deceased members of the Kenya Defence Forces
or”



53. CLAUSE 22

THAT, the Bill be amended by deleting Clause 22.

PART V

5.0 COMMITTEE RECOMMENDATION

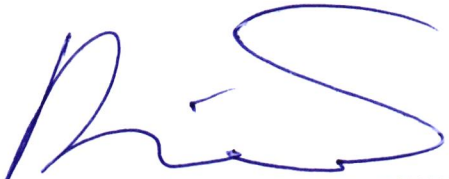
54. The Committee having considered the Military Veterans Bill (National Assembly Bill No. 4 of 2022) recommends that the House approves the Bill with amendments as proposed in the schedule.

SIGNED.......... DATE..........

HON. RICHARD NYAGAKA TONGI, MP

(CHAIRPERSON, DEPARTMENTAL COMMITTEE ON DEFENCE & FOREIGN RELATIONS)

ANNEXURES

MINUTES

MINUTES OF THE ONE HUNDRED AND FIFTY FIFTH (155TH) SITTING OF THE DEPARTMENTAL COMMITTEE ON DEFENCE & FOREIGN RELATIONS HELD AT 5TH FLOOR CONTINENTAL HOUSE, ON TUESDAY, 12TH APRIL, 2022 AT 11.30 AM.

PRESENT

1. The Hon. Richard Tong'i, MP (Chairperson)
2. The Hon. Elijah Memusi Kanchory, MP (Vice-Chairperson) (*Virtually*)
3. The Hon. Charles Kilonzo, MP
4. The Hon. Col. (Rtd) Dido Ali Raso, MBS, MP (*Virtually*)
5. The Hon. (Dr.) Lilian Gogo, MP
6. The Hon. (Dr.) Irene Muthoni Kasalu, MP (*Virtually*)
7. The Hon. Ernest Ogesi Kivai, MP
8. The Hon. Caleb Amisi, MP

APOLOGIES

1. The Hon. (Dr.) Adan Keynan Wehliye, CBS, MP
2. The Hon. Col. (Rtd.) Gideon S. Konchela, EGH, OGW, 'psc' (UK), MP
3. The Hon. Richard Maore Maoka, CBS, MP
4. The Hon. Yusuf Hassan Abdi, MP
5. The Hon. Martha Wangari Wanjira, MP
6. The Hon. Stephen Mutinda Mule, MP
7. The Hon. Maj. (Rtd.) Bashir Sheikh Abdullah, MP
8. The Hon. Moses Nguchine Kirima, MP
9. The Hon. Vincent Kipkurui Tuwei, MP
10. The Hon. Asha Hussein Mohamed, MP
11. The Hon. Zachary Kwenya Thuku, MP

IN ATTENDANCE

NATIONAL ASSEMBLY SECRETARIAT

- | | | |
|------------------------|---|--------------------|
| 1. Mr. Abdiaziz Shobay | - | Clerk Assistant II |
| 2. Ms. Brigitta Mati | - | Legal Counsel |
| 3. Mr. Eric Kariuki | - | Research Officer |
| 4. Mr. John Ngang'a | - | Audio Officer |
| 5. Mr. Mohamed Said | - | Serjeant At-Arm |

MIN. NO.NA/DDC.DFR/2022/074:

PRELIMINARIES

The Chairperson called the meeting to order at 11.40 am and said a prayer. The agenda of the meeting was adopted as hereunder after being proposed by The Hon. Charles Kilonzo, MP and seconded by The Hon. Caleb Amisi, MP.

AGENDA

1. Prayers
2. Adoption of the agenda
3. Substantive agenda: **Consideration and Adoption of the report on Military Veterans Bill, 2022**
4. Any Other Business

MIN. NO.NA/DDC.DFR/2022/075: CONFIRMATION OF MINUTES OF PREVIOUS SITTINGS

152nd Sitting

Minutes of the 152nd sitting held on 1st April, 2022 were read and confirmed as a true record of proceedings as proposed by Hon. Charles Kilonzo, MP and seconded by Hon. Caleb Amisi, MP. There were no matters arising.

153rd Sitting

Minutes of the 153rd sitting held on 1st April, 2022 were read and confirmed as a true record of proceedings as proposed by Hon. Elijah Memusi Kanchory, MP and seconded by Hon. (Dr.) Lilian Gogo, MP. There were no matters arising.

154th Sitting

Minutes of the 154th sitting held on 5th April, 2022 were read and confirmed as a true record of proceedings as proposed by Hon. (Dr.) Irene Muthoni Kasalu, MP and seconded by Hon. Caleb Amisi, MP. There were no matters arising.

MIN. NO.NA/DDC.DFR/2022/076: CONSIDERATION AND ADOPTION OF THE REPORT ON MILITARY VETERANS BILL, 2022

The Committee was taken through the report on the Military Veterans Bill, 2022 and adopted the proposed amendments to the Bill as follows: -

1. LONG TITLE

THAT, the long title to the Bill be amended by deleting the words “to establish the Defence Forces Retirement Home”

2. CLAUSE 2

THAT, Clause 2 of the Bill be amended—

- (a) by deleting the definition of the term “ child” and substituting therefor the following new definition—

“Child” means a child of a Kenya Military Veteran under the age of eighteen years;”

- (b) by inserting the following new definition in its proper alphabetical sequence—

“private entity” means any person or private group, organization, proprietorship, partnership, trust, cooperative, association, corporation, or other commercial or non-profit entity duly established and/or registered under applicable laws in Kenya or in other jurisdictions that accept to co-operate and voluntarily fund any object and/or activity envisaged under this Act including an officer, employee, or agent thereof.

3. CLAUSE 3

THAT, Clause 3 of the Bill be amended by deleting paragraph (d).

4. CLAUSE 6

THAT, Clause 6 of the Bill be amended by—

- (a) deleting paragraph (a);
(b) deleting paragraph (b); and

(c) deleting paragraph (c).

5. **CLAUSE 21**

THAT, Clause 21 of the Bill be amended in sub clause (1) —

(a) in paragraph (a), by deleting the words “ members of the Kenya Defence Forces and”;

(b) in paragraph (b), by deleting the words “ deceased members of the Kenya Defence Forces or”

6. **CLAUSE 22**

THAT, the Bill be amended by deleting Clause 22.

COMMITTEE RECOMMENDATION

7. **The Committee having considered the Military Veterans Bill (National Assembly Bill No. 4 of 2022) recommends that the House approves the Bill with amendments as proposed in the schedule.**

MIN. NO.NA/DDC.DFR/2022/077: ADJOURNMENT

No any other business arose.

MIN. NO.NA/DDC.DFR/2022/078: ADJOURNMENT

There being no other business, the meeting adjourned at 1.35 pm.

Signed.....

**Hon. Richard Tong'i, M.P
(CHAIRPERSON)**

Date.....14/04/2022.....

MINUTES OF THE ONE HUNDRED AND FIFTY SECOND (152ND) SITTING OF THE DEPARTMENTAL COMMITTEE ON DEFENCE & FOREIGN RELATIONS HELD AT INNER-PIER CONFERENCE ROOM, ENGLISH POINT MARINA ON FRIDAY, 1ST APRIL, 2022 AT 9.30 AM.

PRESENT

1. The Hon. Richard Tong'i, MP (Chairperson)
2. The Hon. Elijah Memusi Kanchory, MP (Vice-Chairperson)
3. The Hon. Yusuf Hassan Abdi, MP
4. The Hon. Charles Kilonzo, MP
5. The Hon. Maj. (Rtd.) Bashir Sheikh Abdullah, MP
6. The Hon. (Dr.) Lilian Gogo, MP
7. The Hon. Moses Nguchine Kirima, MP
8. The Hon. Ernest Ogesi Kivai, MP
9. The Hon. Caleb Amisi, MP

APOLOGIES

1. The Hon. (Dr.) Adan Keynan Wehliye, CBS, MP
2. The Hon. Col. (Rtd.) Gideon S. Konchela, EGH, OGW, 'psc' (UK), MP
3. The Hon. Richard Maore Maoka, CBS, MP
4. The Hon. Col. (Rtd) Dido Ali Raso, MBS, MP
5. The Hon. Martha Wangari Wanjira, MP
6. The Hon. Stephen Mutinda Mule, MP
7. The Hon. (Dr.) Irene Muthoni Kasalu, MP
8. The Hon. Vincent Kipkurui Tuwei, MP
9. The Hon. Asha Hussein Mohamed, MP
10. The Hon. Zachary Kwenya Thuku, MP

IN ATTENDANCE

NATIONAL ASSEMBLY SECRETARIAT

- | | | |
|------------------------|---|-----------------------------------|
| 1. Mr. Peter Chemweno | - | Director, Departmental Committees |
| 2. Mr. Daniel Mutunga | - | Principal Clerk Assistant |
| 3. Mr. Abdiaziz Shobay | - | Clerk Assistant II |
| 4. Ms. Brigitta Mati | - | Legal Counsel |
| 5. Mr. Edwin Machuki | - | Fiscal Analyst |
| 6. Mr. Eric Kariuki | - | Research Officer |
| 7. Mr. John Ngang'a | - | Audio Officer |
| 8. Mr. Mohamed Said | - | Serjeant At-Arm |

MINISTRY OF DEFENCE

- | | | |
|----------------------------|---|--------------------------------|
| 1. Hon. Peter Odoyo | - | Chief Administrative Secretary |
| 2. Maj. Gen. A. M Kiugu | - | ACDF P&L |
| 3. Brigadier C.L Mwanzighe | - | Chief compensation and welfare |
| 4. Brigadier K. Kirui | - | Chief of legal services |
| 5. Lt. General Njoroge | - | Ministry of Defence |
| 6. G.F Sakwa | - | Ministry of Defence |

MIN. NO.NA/DDC.DFR/2022/061:

PRELIMINARIES

The Chairperson called the meeting to order at 9.40 am and said a prayer. The agenda of the meeting was adopted as hereunder after being proposed by The Hon. Yusuf Hassan Abdi, MP and seconded by The Hon. (Dr.) Lilian Gogo, MP.

AGENDA

1. Prayers
2. Adoption of the agenda
3. Substantive agenda: **Meeting with the Cabinet Secretary Ministry of Defence on the Military Veterans Bill, 2022**
4. Any Other Business

MIN. NO.NA/DDC.DFR/2022/062: CONFIRMATION OF MINUTES OF PREVIOUS SITTINGS

The agenda item was deferred to the next sitting.

MIN. NO.NA/DDC.DFR/2022/063: SUBMISSION BY THE CHIEF ADMINISTRATIVE SECRETARY, MINISTRY OF DEFENCE ON THE MILITARY VETERANS BILL, 2022

Hon. Peter Odoyo the Chief Administrative Secretary at the Ministry of Defence informed the Committee that the objective of the Bill was to promote the welfare of retired military personnel by enabling them transition from military to citizens. He welcomed the Lt Gen. (Rtd) Humphrey Njoroge who provided a background of the necessity of the Bill by making the following submission regarding the Military Veterans Bill, 2022;-

- i) Highly trained retirees who can still contribute to achievement of National Security Strategy objectives that entails a balanced orchestration of the military, diplomatic and economic instruments of power are relegated to activities such as farming yet they are still capable of being absorbed into both the private and public sectors to offer their expertise;
- ii) Passing of the bill will be a game changer that will provide the legal and institutional framework to structure utilization of highly skilled veterans in transforming Kenya's economy;
- iii) It's important that such personnel with relevant skills to be reabsorbed and considered for government openings to utilize the acquired skills once they retire;
- iv) That the Bill would be important towards addressing the welfare of retired military personnel;
- v) The pension currently paid to retired Generals who retired during president Moi's time was quite low i.e. the retired Gen. Musumba is paid a monthly pension of Kshs. 7,000;
- vi) That the pension of retirees needs to be reviewed since private soldiers who are retiring currently are receiving a monthly pension of over Kshs. 30,000.
- vii) The guiding principle of the Bill is honoring the sacrifices made by military veterans during military service and their role in defense of the Republic of Kenya.
- viii) The Bill will accord special benefits to military veterans that suffer physical or mental disability from their service to the Country;
- ix) Further the Bill will provide a smooth and seamless transition from military service to civilian life by restoring the capability of those with disabilities to the greatest extent possible thereby improving their quality of life.
- x) The Bill does not entitle a person defined as a military veteran under the Bill or that person's dependant to any benefit conferred under the Bill or any other written law merely on the ground of such definition.

Members Observations

- i) Definition of "Child" in the Bill deviates from the definition in the Children Act.
- ii) A private entity needs to be defined in the Bill.
- iii) Military veterans with specialized skills can be absorbed in the private sector once they retire. The Committee noted that Kenya is a developing Country with limited employment opportunities in the private sector with the option of also engaging them on non-monetary and part time basis;
- iv) The Committee observed that retirement homes can create dependency hence discouraging personal investments by the Military personnel, Further, the Committee noted that the practice was considered alienating and depressing as well as inconsistent with the social culture of family and community;
- v) Modalities of establishing an education fund was not clear and whether the fund is to be financed by tax payers;
- vi) The Committee noted that the Bill should be structured in a manner that it is not depicted as a money bill and accordingly restructured so that it highlights the organization and the internal affairs of veterans;
- vii) The committee noted that a strong justification be provided to differentiate the nature of duty in the defense forces from other agencies such as the police.

Committee Recommendations

- i) Reconcile definition of "Child" with the Children's Act. **Justification:** The bill should be amended to align to the definition in the Children's Act; "child" means a child of a Kenya Military Veteran under the age of 18 years.
- ii) Use of the term 'private entity' in clause 7 (3) needs to be defined in the interpretations section to avoid ambiguities. **Justification:** The Proposed definition to be considered for adoption means any person or private group, organization, proprietorship, partnership, trust, cooperative, association, corporation, or other commercial or non-profit entity duly established and/or registered under applicable laws in Kenya or in other jurisdictions that accept to co-operate and voluntarily fund any object and/or activity envisages under this Act including an officer, employee, or agent thereof.
- iii) The reference to Government Ministries, Departments and Agencies involved with military veterans shall co-operate with the Ministry responsible for veterans' matter needs to be redrafted **Justification:** so that the bill does not appear to legislating on existing laws that confer powers and functions to other entities. The Clauses should therefore be redrafted.
- iv) Clause 21 (1) (a) on the Education fund appears to suggest fees will be paid for serving personnel's children, **Justification:** It was agreed that the clause be redrafted to cater for only veterans' children;
- v) In regards to excluding entitlement to benefits for self-inflicted physical and mental disability, **Justification:** It was resolved that the provision be maintained to cater for mischief of personnel who self-inflict injuries as a result of indiscipline or to avoid being deployed or assigned duty. Further, for cases where drug and substance abuse is occasioned by defiance despite interventions.
- vi) Retirement homes should be through contributions by serving military personnel and other staff welfare schemes. They should not overburden the tax payers.
- vii) A private entity should be clearly defined in the bill.

MIN. NO.NA/DDC.DFR/2022/064;

ADJOURNMENT

There being no other business, the meeting adjourned at 1.35 pm.

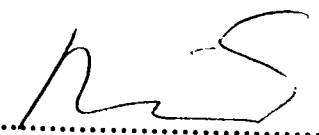
Signed..... 

Hon. Richard Tong'i, M.P
(CHAIRPERSON)

Date..... 12th / 04 / 2022

MINUTES OF THE ONE HUNDRED AND FIFTY FIRST (151ST) SITTING OF THE DEPARTMENTAL COMMITTEE ON DEFENCE & FOREIGN RELATIONS HELD AT COMMITTEE ROOM, 5TH FLOOR, CONTINENTAL HOUSE, PARLIAMENT BUILDINGS ON THURSDAY, 24TH MARCH, 2022 AT 12.00 PM.

PRESENT

1. The Hon. Richard Tong'i, MP (Chairperson)
2. The Hon. Col. (Rtd.) Gideon S. Konchela, EGH, OGW, 'psc' (UK), MP
3. The Hon. Charles Kilonzo, MP
4. The Hon. Col. (Rtd) Dido Ali Raso, MBS, MP
5. The Hon. Martha Wangari Wanjira, MP (Virtually)
6. The Hon. Stephen Mutinda Mule, MP (Virtually)
7. The Hon. Maj. (Rtd.) Bashir Sheikh Abdullah, MP (Virtually)
8. The Hon. (Dr.) Lilian Gogo, MP
9. The Hon. (Dr.) Irene Muthoni Kasalu, MP (Virtually)
10. The Hon. Moses Nguchine Kirima, MP
11. The Hon. Ernest Ogesi Kivai, MP
12. The Hon. Vincent Kipkurui Tuwei, MP (Virtually)
13. The Hon. Caleb Amisi, MP (Virtually)
14. The Hon. Zachary Kwenya Thuku, MP (Virtually)

APOLOGIES

1. The Hon. Elijah Memusi Kanchory, MP (Vice-Chairperson)
2. The Hon. (Dr.) Adan Keynan Wehliye, CBS, MP
3. The Hon. Richard Maore Maoka, CBS, MP
4. The Hon. Yusuf Hassan Abdi, MP
5. The Hon. Asha Hussein Mohamed, MP

IN ATTENDANCE

NATIONAL ASSEMBLY SECRETARIAT

- | | | |
|------------------------|---|--------------------|
| 1. Mr. Abdiaziz Shobay | - | Clerk Assistant II |
| 2. Ms. Brigitta Mati | - | Legal Counsel |
| 3. Mr. Eric Kariuki | - | Research Officer |
| 4. Mr. John Ngang'a | - | Audio Officer |
| 5. Mr. Said Wako | - | Serjeant At-Arm |

MIN. NO.NA/DDC.DFR/2022/056:

PRELIMINARIES

The Chairperson called the meeting to order at 12.15 pm and said a prayer. The agenda of the meeting was adopted as hereunder after being proposed by The Hon. Col. (Rtd) Dido Ali Raso, MBS, MP and seconded by The Hon. Col. (Rtd.) Gideon S. Konchela, EGH, OGW, 'psc' (UK), MP

AGENDA

1. Prayers
2. Adoption of the agenda
3. Confirmation of minutes of previous sittings
4. Substantive agenda: Briefing by Legal Counsel on the Military Veterans Bill, 2022
5. Any Other Business

MIN. NO.NA/DDC.DFR/2022/057: CONFIRMATION OF MINUTES OF PREVIOUS SITTINGS

150th Sitting

Minutes of the 150th sitting held on 15th March, 2022 were read and confirmed as a true record of proceedings as proposed by Hon. Caleb Amisi, MP and seconded by Hon. Zachary Kwenya Thuku, MP. There were no matters arising.

MIN. NO.NA/DDC.DFR/2022/058: BRIEFING BY LEGAL COUNSEL ON THE MILITARY VETERANS BILL, 2022

The Committee was taken through the Military Veterans Bill, 2022 as follows: -

- i) The Bill seeks to establish a regulatory and institutional framework for the management of military veterans' affairs; for the provision of benefits to military veterans and military veterans' dependants; to establish the Dependants' Education Fund; to establish the Defence Forces Retirement Home;
- ii) It is to be noted that the Kenya Defence Forces Act (No. 25 of 2012) provides for the functions, organization and administration of the Kenya Defence Forces pursuant to Articles 232 and 239(6) of the Constitution; gives effect to Article 241 and other relevant Articles of the Constitution, provides for disciplinary matters, among other things. However, it does not address what the Bill seeks to achieve;
- iii) Clause 1 of the Bill contains the short title;
- iv) Clause 2 of the Bill contains definitions of key terms used in the Bill;
- v) Clause 3 of the Bill provides for the principal objects of the Act including the management of military veterans' affairs; the provision of benefits to military veterans and military veterans' dependants; the establishment of the Dependants' Education Fund; and the establishment of the Defence Forces Retirement Home;
- vi) Clause 4 of the Bill provides for the guiding principles of the Act including principles relating to military veterans; policies relating to military veterans and principles for the management of funds relating to military veterans;
- vii) Clause 5 of the Bill provides that the benefits conferred under the Act shall not be conferred on a person merely because that person is a military veteran as defined under the Act;
- viii) Clause 6 of the Bill provides for the meaning of "military veteran", that is, a person who has retired from military service and who had served in the Kenya Defence Forces, the Kenya Armed Forces after 1963, or in the Kings African Rifles before 1963; has completed service in the Armed Forces or Kenya Defence Forces, receives a military pension and who was not dishonorably discharged from military service;
- ix) Clause 6 also provides that a person who was discharged or retired from the Armed Forces or Kenya Defence Forces on medical grounds shall, whether or not that person receives a pension, be regarded as a military veteran except if the person suffers from a physical or mental disability that was self-inflicted or occasioned by the use of narcotic drugs or psychotropic substances;
- x) Clause 7 of the Bill provides for the benefits conferred under the Act to military veterans and military veterans' dependants; the role of the Defence Council in the provision of those benefits; the obligations of Government ministries, the departments and agencies; and the role of the Principal Secretary in the ministry responsible for military veterans;
- xi) Under clause 7, the benefits that may be conferred on a military veteran are Counseling and treatment for post-traumatic stress or related conditions, Physical rehabilitation for any condition arising out of military service, Honoring and memorializing fallen military veterans, Education, training and skills development,

- Facilitation or advice on employment placement and Facilitation or advice on business opportunities;
- xii) Under clause 7, the following benefits may be conferred on a military veterans' dependants: Counseling and treatment for post-traumatic stress or related conditions, Facilitation or assistance in education placement for children of military veterans, Facilitation or advice on employment placement and Facilitation or advice on business opportunities;
 - xiii) Clause 8 of the Bill provides for the powers of the Defence Council under the Act;
 - xiv) Clause 9 of the Bill establishes the office of the Director of Military Veterans and places it under the supervision of the Chief of Defence Forces;
 - xv) Clause 10 of the Bill provides for the functions of the Director;
 - xvi) Clause 11 of the Bill provides for the establishment of the Advisory Committee on Military Veterans, its membership and the appointment of its members;
 - xvii) Clause 12 of the Bill provides for the qualifications of the members of the Advisory Committee;
 - xviii) Clause 13 of the Bill provides for the procedure for the filing of vacancies in the Advisory Committee;
 - xix) Clause 14 of the Bill provides for the tenure of the members of the Advisory Committee;
 - xx) Clause 15 of the Bill provides for the determination of the remuneration and allowances of the members of the Advisory Committee;
 - xxi) Clause 16 of the Bill provides for the procedure for the removal from office of a member of the Advisory Committee;
 - xxii) Clause 17 of the Bill provides for the manner in which a vacancy may arise in the Advisory Committee including notice periods in case a member wishes to resign from office;
 - xxiii) Clause 18 of the Bill provides for the functions of the Advisory Committee;
 - xxiv) Clause 19 of the Bill provides for the reports of the Advisory Committee to the Defence Council;
 - xxv) Clause 20 of the Bill provides for the procedure for the convening of the meetings of the Advisory Committee and the obligation to declare conflicts of interest regarding any matter being considered by the Advisory Committee;
 - xxvi) Clause 21 of the Bill provides for the establishment of the Dependants' Education Fund to provide scholarships for the children of members of the Kenya Defence Forces, military veterans or deceased service members or deceased veterans;
 - xxvii) Clause 22 of the Bill provides for the establishment of the Kenya Defence Forces Retirement Home to provide residential and other services to military veterans;
 - xxviii) Clause 23 of the Bill provides for the making of Regulations by the Cabinet Secretary for the better carrying out of the provisions of the Act.

Committee Resolution

The meeting noted that the bill was bulky and required adequate time for its perusal, article by article. The committee resolved to undertake a retreat with the Ministries of Defence and East African Community & Regional Development in Mombasa County from 31st to 4th March, 2022, to consider the Military Veterans Bill, 2022 and the Regional Development Authorities Bill, 2021. During the said retreat the Committee will also meet with the Ministry of Foreign Affairs on the Asset Acquisition and Maintenance Policy and the operationalization of the Foreign Service Act.

MIN. NO.NA/DDC.DFR/2022/059:

ANY OTHER BUSSINES (AOB)

1. The meeting was informed that the Ministry of Defence had invited seven members of the Committee to attend the pass out graduation for Cadets at the Kenya Military Academy, Nakuru on Thursday, 31st March, 2022. Members were requested to confirm attendance with the secretariat.
2. The secretariat reported that they had received letters from both the Director of Criminal Investigations (DCI) and the Inspector General of National Police Service (NPS) apprising the Committee on the steps taken to ensure justice for Ms. Agnes Wanjiru, allegedly murdered by the British soldier(s) based in Nanyuki. The letter indicated as follows:-
 - i) That the homicide detectives have concluded investigations in Kenya and the remaining bit was both Kenya and the United Kingdom teams to get information from the witnesses in the United Kingdom for harmonization of the revised Mutual Legal Assistance guidelines (MLA);
 - ii) The DCI team investigating the matter has been in contact with the Royal Military Police of the United Kingdom of Great Britain informally to establish the all Mutual Legal Assistance issues are well addressed and properly identified;
 - iii) The United Kingdom Authorities have already identified the residential mapping of all the possible witnesses and the suspect in the United Kingdom for logistical and operation purposes;
 - iv) The Mutual Legal Assistance has already been forwarded to the Hon. Attorney General for onward transmission to the United Kingdom, Central Authority and waiting for their consent for the DCI team to travel to the United Kingdom to finalize the investigation and commence extradition process of the suspects.

MIN. NO.NA/DDC.DFR/2022/060:

ADJOURNMENT

There being no other business, the meeting adjourned at 1.35 pm.

Signed.....

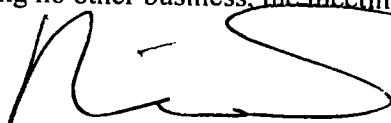

Hon. Richard Tong'i, M.P
(CHAIRPERSON)

Date.....

05/04/2022

**MILLER & COMPANY ADVOCATES
INSTRUCTED BY CAPT' (Rtd.) ERNEST
KAMAU (20813)**



*D/DC
Please deal-
Earl
11/03/22*

*Daniel Mutunga
John Mugo
pls facilitate
14/3/22*

**The Clerk of the National Assembly,
P.O. Box 41842-00100,
NAIROBI.**

Date: 10th March 2022

Dear Sir,

**RE: PUBLIC PARTICIPATION (SUBMISSION OF MEMORANDA) TO THE
TWELFTH PARLIAMENT (SIXTH SESSION)**

**DEPARTMENTAL COMMITTEE ON LABOUR AND SOCIAL WELFARE AND
THAT ON DEFENSE AND FOREIGN RELATIONS**

We are instructed to write to you by our client **Ernest Kinyua Kamau, Service Number 20813, Rank: Captain (retired)** as follows: -

We refer to the notice dated **24th February 2022** in the national newspaper (copy attached) and wish to humbly present our client's views and recommendations as part of public participation as regards the: - **Military Veterans Bill (National Assembly Bill No. 4 of 2022).**

Our client has perused the said bill and the same is a noble idea. He however wants to bring your attention to **page 75, Part 11 6 (1) (d) and (e)** which states:

A Kenyan Citizen shall be regarded as a military veteran for the purposes of this Act if that Kenyan Citizen: -

- d) Has completed service in the Armed Forces or Kenya Defense Forces;
- e) Receives a pension from the Armed Forces or Kenya Defense Forces;

Our client is of the humble view that Sections (d) and (e) are discriminatory in as far as they imply that you must serve to the end of your service or have reached retirement age with a pension in order to qualify as a veteran.

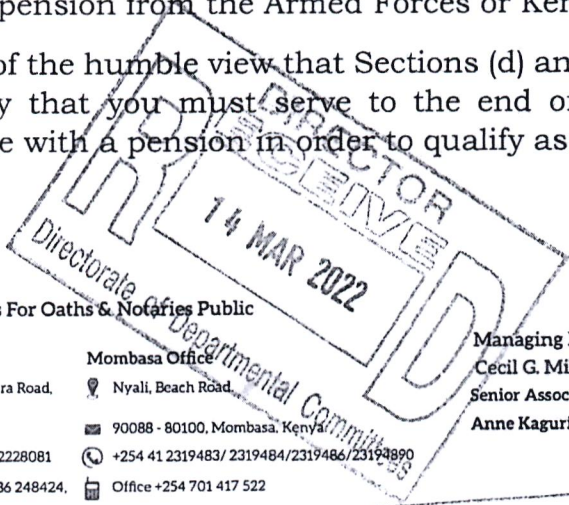

Advocates, Commissioners For Oaths & Notaries Public

Head Office

8th Floor, Flamingo Towers, Mara Road, Upper Hill.

45707 - 00100, Nairobi, Kenya.

Tel: +254 20 2248461, 2248467, 2228081

Office: +254 727 531005, +254 736 248424, +254 724 216991

miller@milleradvocates.com

Mombasa Office

Nyali, Beach Road.

90088 - 80100, Mombasa, Kenya

+254 41 2319483/ 2319484/2319486/23194890

Office +254 701 417 522

www.milleradvocates.com

Managing Partner

Cecil G. Miller

Senior Associate

Anne Kaguri

Associates

Eric Mugo

David Chege

Mary Chege

Grace Mushokambere

Mary Mwangi

Joram Wang'ombe

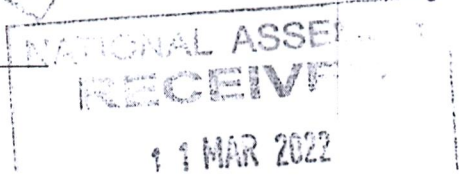

Section 6 (2) states:

Despite Subsection (1) a person who has discharged or retired from the Armed Forces or Kenya Defense Forces on medical grounds shall, whether or not that person receives a pension, be regarded as a military veteran.

Section 6 (2) above seems to imply that the only way one can be a veteran is either through medical discharge, and if not that then Part II Section 6 (1) (d), (e) and (f) then apply.

The problem with this is that it discriminates against those who retire or terminate and are not on pension, and were not dishonourably discharged.

Serving military officers do also retire or terminate on compassionate grounds or voluntarily and this seems to have been omitted from the draft bill herein.

Page 75, Section 6 Part 11 (1) (d) and (e) need to be deleted.

We look forward to a favorable consideration of our client's instructions.

Yours faithfully,

For: - Miller & Company Advocates



Cecil G. Miller

cmiller@milleradvocates.com

/cm

**NATIONAL GENDER AND EQUALITY
COMMISSION (NGEC)**



National Gender and Equality Commission
 1st Floor, Solution Tech Place, 5 Longonot Road, Upper Hill, Nairobi
 P.O. OX 27512-00506 Nairobi, Kenya
 Landline: +254 (020)3213100
 Mobile: +254 (020)375100
 Toll Free: 0800720187
 www.ngeckeny.org
 Email: info@ngeckeny.org

Daniel Mutunga
 to facilitate
 up to 16/3/2022
 11th March 2022

When replying please quote

Ref: No: NGEN/CS/NAS/005/VOL. I (69)

Michael R. Sialai, CBS
 Clerk of the National Assembly
 Clerk's Chambers
 Parliament Building
 P.O. Box 41842-00100
 NAIROBI

clerk@parliament.go.ke

Dear Mr. Sialai,

**SUBMISSION OF MEMORANDA ON THE MILITARY VETERANS BILL, 2022
 (NATIONAL ASSEMBLY BILL NO 4 OF 2022)**

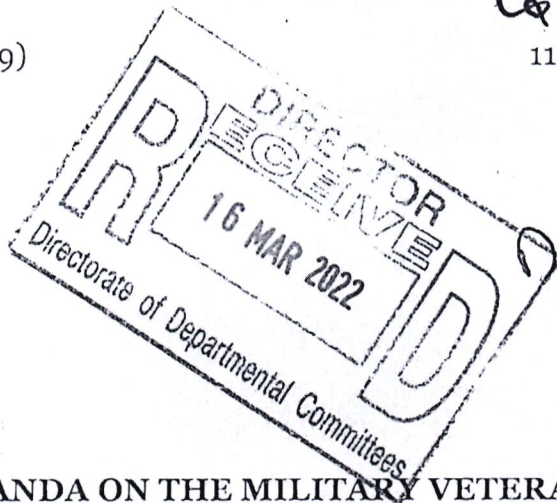

D. Mutunga
 8/15/3

Reference is made to your call for the submission of memoranda on the Military Veterans Bill, 2022.

The National Gender and Equality Commission (NGEC) is a Constitutional Commission with the mandate of promoting and ensuring gender equality, principles of equality and non-discrimination for all persons in Kenya, with a focus on Special Interest Groups (SIGs) who include women, children, Persons with Disabilities (PWDs), youth, older members of society, minority and marginalized groups.

Section 8 (b) of the National Gender and Equality Commission Act, No. 15 of 2011 mandates the Commission to, 'monitor, facilitate and advise on the integration of the principles of equality and freedom from discrimination in all national and county policies, laws, and administrative regulations in all public and private institutions'.

The proposed Bill seeks to take care of the welfare of military veterans among them the old, and those who acquired physical and/or mental disabilities while in service.

In line with its mandate, the Commission wishes to submit the attached Memorandum analyzing the proposed amendments and making proposals where necessary.

Yours sincerely,

Betty Sungura-Nyabuto

Betty Sungura-Nyabuto MBS
COMMISSION SECRETARY/ CEO

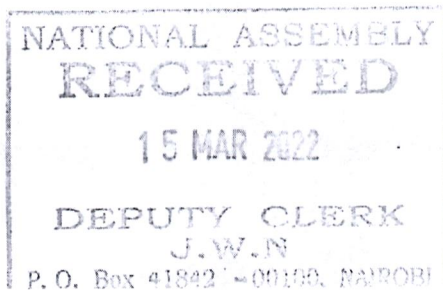

ATIONAL GENDER AND EQUALITY COMMISSION



MEMORANDUM WITH COMMENTS AND INPUTS ON THE MILITARY VETERANS BILL, 2021

Submitted to: clerk@parliament.go.ke

PROVISION	PROPOSAL AMENDMENTS	FOR	RATIONALE/JUSTIFICATION
<p>New proposed interpretations</p> <p>Military Veteran</p>	<p>“Military veteran” means a person who served in the active military, naval, or air service, and who was discharged or released therefrom under conditions other than dishonorable.</p>		<p>The term has not been interpreted.</p>
<p>PART II – MILITARY VETERANS BENEFITS</p> <p>Clause 6</p> <p>(2) Despite subsection (1), a person who was discharged or retired from the Armed Forces or Kenya Defence Forces on medical grounds shall, whether or not that person receives a pension, be regarded as a military veteran : Provided that if the person suffers from a physical or mental disability that was self-</p>	<p>The Commission proposes to amend by deleting the entire proviso in clause 6(2) i.e from the word “Provide” onwards to the end including (3).</p>		<p>The justification for the proposal is to expand the list of beneficiaries from services such as</p> <p>(a) counselling and treatment for post-traumatic stress or related conditions;</p> <p>(b) physical rehabilitation for any condition arising out of military service;</p> <p>It has been noted that many of the armed forces officer suffer mental health issues and</p>

<p>inflicted or occasioned by the use of narcotic drugs or psychotropic substances, that person shall not be considered a military veteran for the purposes of this Act.</p> <p>(3) For the purposes of this section, "narcotic drugs and psychotropic substances" have the same meaning assigned to them under section 2 of the Narcotic Drugs and Psychotropic Substances (Control) Act, 1994; and</p>		<p>sometimes results into taking drugs : comfort. It is important to support su groups to fir well in the civilian world.</p>
<p>3. ESTABLISHMENT OF THE ADVISORY COUNCIL</p> <p>Clause 11</p> <p>(1) There shall be established an advisory committee to be known as the Advisory Committee on Military veterans (2) The Advisory Committee shall comprise of—</p> <p>(a) a chairperson appointed by the President on therecommendation of the Defence Council; and</p> <p>b) six other members appointed by the Defence Council.</p> <p>3) An appointment under this section shall be by name and notice in the Gazette.</p> <p>(4) In making appointments under subsection (2) (b), the Defence Council shall ensure that—</p> <p>a) not more than two-thirds of the members of the Advisory Council are of the same gender, and</p>	<p>Amend by including other stakeholders that include -;</p> <ol style="list-style-type: none"> 1. The parent Ministry 2. The Department of social Protection 3. Ministry of National Planning and Treasury 4. Faith based organisations and civil societies. <p>Amend the composition of the officers appointed to include -;</p> <ol style="list-style-type: none"> i. A veteran with disability ii. An Elderly veteran. 	<p>The proposed composition does not meet the threshold provided for in the <i>Mwongoc</i> code of governance - i.e. Must have mix skills and competencies required - At least one member to be a financial expert.</p> <p>We note the entire proposed composition drawn exclusively from the defense forces.</p> <p>Veterans who are elderly and have disabilities acquired in the line of service have lived experience and can benefit from the Advisory Council.</p>

<p>b) at least one member each shall be a retired senior officer, junior officer and service member.</p> <p>(5) The Director shall be the secretary to the Advisory Committee</p>		
<p>PART IV- DEPENDANTS' EDUCATION FUND</p> <p>21. (1) The Defence Council shall establish a fund to be known as the Dependants' Education Fund to provide scholarships for the education of the children of-</p> <p>(a) members of the Kenya Defence Forces and military veterans; and</p> <p>(b) deceased members of the Kenya Defence Forces or deceased military veterans.</p> <p>(2) The Defence Council shall prescribe Regulations for the administration of the Fund including the procedure for processing applications or scholarships from the Fund.</p> <p>(3) All receipts, earnings and accruals to the Fund, and the balance of the Fund at the close of each financial year shall be retained by the Fund for use for the purpose for which the Fund has been established.</p> <p>(4) The Fund shall be established and administered in accordance with the provisions of the Public Finance Management Act, 2012.</p>	<p>Delete the entire clause without any replacement.</p>	<p>Clause 21(4) states that the Fund shall be established and administered in accordance with the provisions of the Public Finance Management Act, 2012. However-;</p> <p>The PFMA Act Section 24 has the following provisions on establishment of funds under the Act-;</p> <p>4) The Cabinet Secretary may establish a national government public fund with the approval of the National Assembly.</p> <p>(5) The Cabinet Secretary shall designate a person to administer every national public fund established under subsection (4).</p> <p>(6) The administrator of a national public fund shall ensure that the earnings of, or accruals to a national public fund are retained in the fund unless the Cabinet Secretary directs otherwise.</p> <p>(7) The administrator of a national public fund shall ensure that money held in the fund, including any earnings or accruals referred to in subsection (6), is spent only for the purposes for which the fund is</p>

		<p>established</p> <p>Remarks</p> <p>The Council lacks the mandate to establish Fund and administer it under the PFM Act</p> <p>Due process should therefore be followed enable the Cabinet Minister, National Planning and Treasury to establish a Fund.</p> <p>The Advisory Council can consider expanding the purpose of the Fund so that is not only limited to the education of dependents but to fund Social protection for the needy veterans (elderly and with disabilities) and for establishment and maintenance of retirement homes in Counties.</p>
<p>5.</p> <p>Defence forces home retirement</p> <p>22. (1) The Defence Council shall establish a retirement home to be known as the Defence Forces Retirement Home to provide residential and related services to military veterans.</p> <p>(2) The Defence Council shall prescribe Regulations for the achievement of the objects of this section and notwithstanding the generality of the foregoing, the Regulations may provide for—</p> <p>(a) persons who shall be eligible to reside in the Defence Forces Retirement Home;</p>	<p>Define what a retirement home is.</p> <p>Consider establishing more than one home and outreach centers in the counties where most of the veterans who need support reside.</p> <p>Include a provision on source of funds to enable the council execute its mandate.</p>	<p>The Bill does not have financial provisions establishing a retirement home and pay allowances but there is no source of funding provided for.</p>

<p>(b) the services to be provided in the Defence Forces Retirement Home;</p> <p>(c) contributions to be made by members of the Kenya Defence Forces with respect to the Defence Forces Retirement Home; and</p> <p>(d) any other relevant matter relating to the Defence Forces Retirement Home.</p>		
<p>PART VI Regulations.</p> <p>23.(1) The Defence Council may make Regulations, generally for the better carrying out of the provisions of this Act.</p> <p>(2) Despite the generality of subsection (1), the Regulations made under this section may provide for—</p> <p>(a) the manner of accessing any benefit provided under this Act; and</p> <p>(b) any matter required or permitted to be prescribed by or in accordance with this Act</p>	<p>Amend by substituting the word “Defence Council” with “The Cabinet Secretary” whenever it appears in this Clause 23(1)</p>	<p>The mandate of making Regulations is bestowed on the Cabinet Secretary in charge of implementing the enacted law.</p>

additional notes by the Commission for noting

On June 1st, 2019, The President of Kenya indicated in his official Madaraka Day speech that the country was facing a mental health crisis, and ordered the Ministry of Health to implement programs and policies to address the problem. A Cabinet meeting held on 21st November, 2019, went further and directed the formation of a Mental Health Taskforce to address the mental health concerns of Kenyans and help guide the government on resource allocation for mental health. On December 11th, the Taskforce was inaugurated and given 80 days in which to complete the work and the report attached contains submissions and recommendations on disciplined forces: Taskforce on Mental Health Report 16_lowres.pdf. The armed forces made their presentations and it was clear that they have specific needs that arise from the nature of their work.

More specifically, the participants in the armed forces wanted decriminalization of suicide, policy changes within the forces and more attention paid to mental health awareness. They expressed concern about the high number of persons with mental health conditions in the midst due to the nature of their work.

The Taskforce heard that officers who die by suicide are discharged dishonorably and hence their families do not get any compensation or suffering twice.

Some of the key recommendations by the task force

- a. The different security service institutions must provide psychological services for both managers and staff at disciplinary institutions.
- b. The institutions should establish regular staff support sessions on mental health in workplaces for the officers.
- c. The government through the Ministry of Health should mainstream mental health in all sectors including the disciplinary forces.

As you review this Bill, we invite you to consider the above summary.

**UGUNYA/UGUNJA VETERAN
DEVELOPMENT GROUP**

UGUNYA/UGUNJA VETERAN DEVELOPMENT GROUP

P.O BOX, 87-40606,

UGUNJA.

09/03/2022.

*2 John Mwangi
pk fahidate
14/3/22*

*1 D/DC
Please deal
Suli
11/03/22*

*3 Mr Mwangi
Re deal
Mwangi D/DC
15/3/22*

TO CLERK OF THE NATIONAL ASSEMBLY,

P.O BOX, 41842-00100

NAIROBI.

Dear Sir/Madam

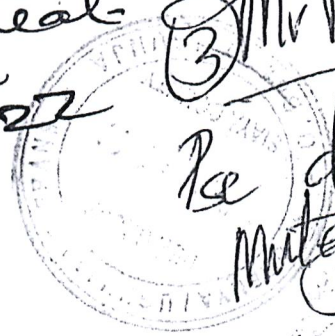
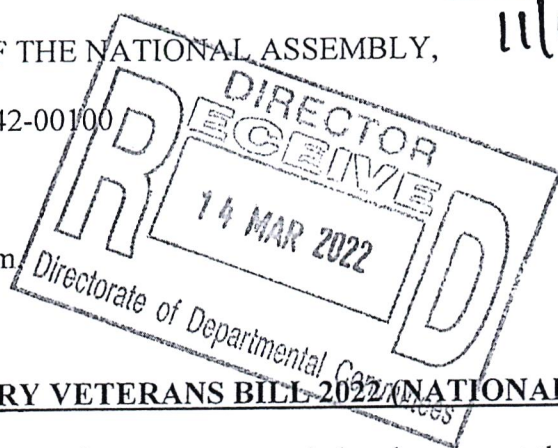

REF: MILITARY VETERANS BILL 2022 (NATIONAL ASSEMBLY BILL 04 2022).

We the Ugenya/Ugunja veteran group do hereby support the bill fully, with our request or prayer on the following.

1. PENSION
 - a. If an officer or service member retires in the year 2022 and earns a given sum in his/her pension in comparison to the one who retires in the year 2004, the difference of margin in pension paid creates a social/economic impact.
 - Case study; senior private who retired in the year 2003 in comparison to the one retiring in the year 2022 has a big difference in their pension dues.
 - To address this issue we need to bring them to the same level in line with the current retiring senior private.
 - b. Spouse as a veteran;
 - Spouse has administrative responsibility including children.
 - Spouse as an administrator of the late veterans estate, he/she should receive the pensions of the late veteran's pension till his or her demise.
2. DEFMIS
 - a. Outpatient cases- we request for the waiver of 25% on the outpatient services.
 - b. Inpatient cases- we request for consideration of a veterans to be admitted to the private wing as in contrast to admission in general wards.
 - Veterans should be accorded services of private wing on those accredited hospitals on admission.
 - Case study; comparatively with the Teachers Service Commission who provides for their members private facilities on admission in contrary to the veterans.

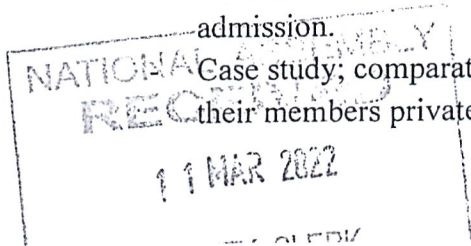

3. LAST RESPECT.

We request the DEFMIS to cater for funerals services for the departed veterans eg, Coffin, Hearse etc.

Yours faithfully,



TOM JUMA OTIENO

SECRETARY UGENYA UGUNJA VETERANS GROUP.

THE UGENYA UGUNJA VETERAN GROUP

PUBLIC PARTICIPATION HELD AT SEGA VICTORIA HOTEL ON 1ST MARCH, 2022

MILITARY VETERANS BILL 2022 (NATIONAL ASSEMBLY BILL 04 2022)

IN ATTENDANCE

/N	SVC NO.	RANK (RTD)	NAME	ID NO.	TEL NO.	SIGN
	10355	WO1	BONFACE OWINO KOTAYA	0403340	0721108498	<i>[Signature]</i>
	54132	SGT	JOSEPH MESO OKUMU	3498359	0723708305	<i>[Signature]</i>
	14015	SSGT	STEPHEN ODONGO OMOGA	6443689	0711401450	<i>[Signature]</i>
	8820	CPL	DIDACUS ONDENG	8281770	0723452564	<i>[Signature]</i>
	6424	SGT	GEORGE OOKO OMUANDA	3420530	0727593515	<i>[Signature]</i>
	9441	WO1	GEORGE OTIENO NGALA	3421251	0722596396	<i>[Signature]</i>
	8084	SGT	JOHN ODHIAMBO OBIMBO	0333563	0701393201	<i>[Signature]</i>
	100155	WO1	JOSEPH OUMA ODUOR	4343258	0722244368	<i>[Signature]</i>
	4815	WO1	JAMES OHOMO OWINO	4342315	0713031665	<i>[Signature]</i>
	6424	SGT	GEORGE OKELO ODONGO	3420830	0727593515	<i>[Signature]</i>
	52242	SPTE	MORICE ODINGA ABELE	1254542	0712224238	<i>[Signature]</i>
	8227	WO2	ANTONEY ODHIAMBO ABOKA	0402082	0722454866	<i>[Signature]</i>
	7075	WO2	GEORGE OWINO WASAMBLA	3283677	0721896697	<i>[Signature]</i>
	10125	SGT	SILAS OTIN SIRA	4878251	0723232935	<i>[Signature]</i>
	3816	WO1	JACOB NDAR	4342662	0721449290	<i>[Signature]</i>
	54697	SGT	CHARLES ODUOR NGWAVE	1161690	0714368003	<i>[Signature]</i>
	1431	WO2	ALEXANDER OKELO	0436471	0721354671	<i>[Signature]</i>
	865	WO2	CLEON ELIJAH OLOO	1883355	0721410625	<i>[Signature]</i>
	5360	SGT	CHRISTOPHER ODERO OPIYO	3645052	0721472154	<i>[Signature]</i>
	10699	SGT	SYLVESTER OPANY ODUOR	3465161	0703557342	<i>[Signature]</i>
	52558	SSGT	CHRISPINE OKELO	2712069	0721573164	<i>[Signature]</i>
	7689	SGT	OBIERO NYANGAO BOB	2310994	0792969978	<i>[Signature]</i>
	15002	SGT	DISHON OKELO	1328538	0713695266	<i>[Signature]</i>
	7113	WO2	APOLO OPONDO ONYANGO	3283680	0720364424	<i>[Signature]</i>
	10297	WO1	VINCENT SIKUKU	0403696	0722315638	<i>[Signature]</i>



6	9798	WO1	LINUS OTIENO ODUOR	6894315	0722466134	SASA
7	2063	WO1	ALOYS M.O. OMOLLO	4342602	0720938865	R
8	15789	CPL	TOM JUMA OTIENO	0526499	0705136515	S
9	4808	WO2	LUCAS OCHOL ODAKO	3465840	0721559781	SODIOW
0	100394	CPL	FRANCIS VICTOR AOOKO	14544237	0724421744	U
1	54169	SSGT	NICHOLAS OKOTH MARAMBA	4591147	0726546588	U
2	10362	SSGT	JOHNSON AMENYA ODUONG'	0403775	0721594486	U
3	13642	WO2	JOSEPH OLIMA	2074200	0720053394	U
4	5244	SSGT	WELLINGTON WANDO	5973249	0788442927	U
5	12555	WO2	DANIEL ODHIAMBO ODERA	0301644	0722967367	U
6	11583	SSGT	VITALIS OTENGO OLOO	0966004	0723249571	U
7	10928	WO1	SHADRACK SAM ONYANGO	039696	0722320403	U
8	13972	WO1	LEONARD OCHIENG OHOHO	1164618	0722448528	U
9	104147	SGT	PETER OTIENO AREKA	8215602	0722276717	U
0	16803	WO1	CHARLES OGOLLA OSINO	0652248	0722257672	U
1	9115	WO2	ALEXANDA OMONDI	5992409	0114351738	U
2	10293	WO1	JULIUS OKOTH	5992496	071075924-	U
3	10760	WO2	JOANES AGENGO	7558299	0722442591	U
4	10321	SSGT	PHILIP ODUOR OKUMU	0403521	0723911246	U
5	54308	WO2	THOMAS ODHIAMBO OМУYA	6945171	072290364	U
6	15781	WO2	PAUL OWINO ZAKARIA	4028033	0728351827	U
7	32121	WO2	ISAAC AKUMU	8215330	0700168784	U
8	56829	WO2	JOSEPH ONYANGO YUAYA	5789953	0720979575	U
9	52554	WO1	VITALIS ONYANGO OOKO	6947673	0720336780	U
0	15791	SSGT	CLEOPHAS OMONDI ODUOR	61735877	0721407743	U
1	14810	SSGT	NICHOLAS OTIENO ODUOR	3243587	0723889962	U
2	56570	WO2	FREDRICK OTIENO ODHIAMBO	1161874	0721424216	U
3	17855	CPL	ELPHAS ARONY OMOLO	3464371	0718362630	U
4	55246	WO2	PATRICK OCHIENG OBIYA	6447310	0720662781	U
5	5887	SSGT	FRANCIS OMONDI ODHIER	4074081	0710484065	U





Certificate No. 266464

Republic of Kenya

MINISTRY OF GENDER, CHILDREN & SOCIAL DEVELOPMENT

Certificate of Registration of Self-help Group/Project

This is to Certify that

UGENYA/UGUNJA VETERAN DEVELOPMENT GROUP

Group Name

UGU/S.H/0027

7TH FEBRUARY, 2012

Registration No.

Date of Registration

NGUNYA

UGENYA CENTRAL

Sub-location / Ward

Location

UGUNJA

UGUNJA

Division

District

UGENYA

Constituency

is registered with the office of the District Gender & Social Development Officer (DGSDO) as a Self-Help

Group/Project
**DISTRICT GENDER AND SOCIAL
DEVELOPMENT OFFICER
UGUNJA DISTRICT**

For: District Gender & Social Development Committee

UGUNJA

District

7TH FEBRUARY, 2012

Date of Issue

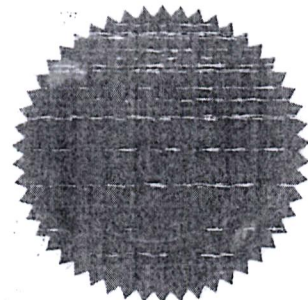



www.kra.go.ke

Personal Information and Return Filing Details			
Taxpayer PIN	P051700599Z	Return Period	07/02/2012 - 31/12/2012
Name and Address	Ugenya/ugunja Veteran Development Group N/A, UGUNJA, Ugunja District, 40606, 87.		
Tax Obligation(Form Name)	Income Tax Company(IT2C)	Original or Amended	Original
Station	Kisumu	Acknowledgement	27/02/2019 13:34:03
Return Number	KRA201902249963	Barcode	

Return Summary		
Sr.	Particulars	Amount (Ksh)
1.	Adjusted Taxable Income	0.00
2.	Compensating Tax Balance	0.00
3.	Tax Payable	0.00
4.	Compensating Tax Payable	0.00
5.	Total Tax Payable	0.00
6.	Tax Credits	0.00
7.	Tax Due / (Refund Due)	0.00

Note : We acknowledge receiving your Return through KRA web portal. This data has been forwarded to the concerned area officer for further processing. You can track your status by using search code from web portal.

Search Code: 814497754657LCV



Notice: Employers are reminded that the due date for PAYE Returns and remittance is the ninth day of each calendar month.

**CREATIVE INDUSTRIAL ARTS
TECHNOLOGISTS ASSOCIATION OF
KENYA**

1 D/DC
Please deal.
11/03/22

2 John meyome
pls facilitate
14/3/22

CREATIVE INDUSTRIAL ARTS TECHNOLOGISTS ASSOCIATION OF KENYA

P.O. box 388, 00902 KIKUYU Tel 0722566431

Email: ciatak2017@gmail.com

Clerk of the National Assembly
Republic of Kenya
Dear Sir/Madam.

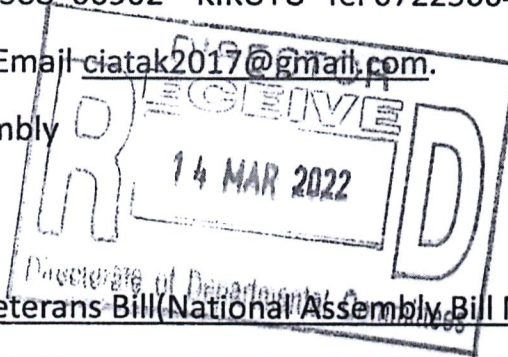

3 Mr. Mutegye
Pse deal
Mutegye
10-3-2022
15/3/22

Ref: The Military Veterans Bill (National Assembly Bill No 4 Of 2022)

MEMORUDUM TO RECOGNIZE AND ESTABLISH A SECTOR FOR RETIRED MILITARY TECHNOLOGISTS WITHIN THE GOVERNMENT INDUSTRIALIZATION FRAME WORK

Preamble:

The Bill seeks to establish a regulatory and Institutional frame work for the management of Military Veterans' affairs for the provisions of benefits to Military Veterans dependants to establish the dependants Education funds, establish retirement homes and for connected purposes.

Retired veterans members of K.D.F wish to submit this Memorandum:

The Bill to recognize, assist the establishment of CREATIVE INDUSTRIAL ARTS Sector, which will serve as an added benefit to the Veterans as they continue working on self-creative skills which are enjoyable and fulfilling to the individual this creates an avenue for Kenya Government Industrialization Policy frame work vision 2030 and beyond in a Digital World.

1. AIMS AND OBJECTIVES:

- a. To bring together the skillful brains of retired members of the Defense and security Forces in order to:
 - i) To recognize the Defense Forces acquired skills for Creative Industrial Arts Development.
 - ii) To Promote and use the acquired technology skills in various economic subsectors for National Industrial Development.
 - iii) The sector will collaborate with the government economy development initiatives when called upon to do so.



2. Functions of Industrial Arts:

- i. Metal Work
- ii. Aviation
- iii. Automobile
- iv. Electrical/Electronic
- v. Communication,
- vi. Building and Construction
- vii. Agricultural products
- viii. Security systems
- ix. Textile.
- x. Entertainment.
- xi. Para Medical practices
- xii. Sports and Athletes
- xiii. Any other Industrial art the members may have acquired through pedagogical progression

3. BROAD OBJECTIVES:

- i) To initiate Technology and business development initiatives from the skills acquired by the retired personnel's of defense and security forces.
- ii) To form a retirees SACCO: for Industrial Arts Technology and Business Development services
- iii) To initiate techniques for rebuilding community based family cottage industries, communities are engaged in social enterprise development through Do It Yourself Technology
- iv) To Market the creative industrial technology to all Counties of Kenya and other countries outside Kenya.
- v) To create an enabling social environment to new retirees through creative arts social clubs.
- vi) To enhance the rehabilitation of the upcoming entrepreneurs in various creative technologies in order to bring the joy and freedom of working to every individual
- vii) To bring and create new life to retired men/women through social entrepreneurship engagement.
- viii) To form business partnership
- ix) To liaise with Donors and other funding institutions to improve Training Facilities and business performance in general.
- x) To develop and improve sub-sectoral curriculum to suit modern creative arts Technology.
- xi) To market products of the retired men/women' and their beneficiaries to international and local markets through holding local and international exhibitions

- xii) To accelerate the rate of industrialization through (Do It Yourself) practical projects
- xiii) To enhance relevant applied research for faster national technological growth in line with the governments industrialization objectives (Vision 2030).
- xiv) To network entrepreneurs to expose them to modern and upcoming World of Digital Technologies.
- xv) To market relevant technologies through such forms as exhibitions, the internet and other upcoming media
- xvi) To link the retirees with affordable sources of credit and venture capital to improve their capacity transferring technologies, partnerships with local and foreign research institutions
- xvii) To seek sponsorship training and technology transfer by linking entrepreneurs to donors and their agents.
- xviii) To seek sponsorship and grants from willing donors so as to make training and technology transfer affordable.
- xix) To work in partnership with the Kenya Government in addressing the issues of Technology and business development for Micro and small Enterprises training, aiming at employment creation for poverty reduction.
- xx) The Sector will try to rehabilitate the victims of conflicts in order to make them adaptive and productive in civilian life.
- xxi) The Sector may establish apprenticeship institutions of different kinds of different levels as and when they are required.
- xxii) To provide recreational facilities for members in athletic games, sports, tournaments and exhibitions/galleries.

The sector will reduce the wastage of long earned skills from the Military Technologists after retirement.

WORK IS THE FOUNDATION OF HUMAN RESOURCE DEVELOPMENT

Any nation's most priceless resource is its human, potential. Economic wealth and national security are all derived' from the freedom of people to serve and to grow, working using individual talents to work at an occupation that is fulfilling and productive. The development of the human potential and social and economic wealth all center around a concept of work.

Strengths Arising From Military Experiences

Military experiences has provided veterans with training and work experience that has been used by countries to advance their Technology and Business Development activities. The Government can use the already acquired Technology skills from the retired veterans of the Defense Forces for national industrialization process.

Some of the strengths that many veterans have acquired and used in the uniformed services are:

1. Leadership Training: The military trains people to accept and discharge responsibility for other people, for activities, for resources, and for one's own behavior. This training includes setting an example, giving carefully considered directions, inspiring leadership capabilities in others, and continually motivating other personnel in the group.

2.Ability to Work as a Team Member and as a Team Leader: Essential to the military experience is the ability to work as a member of a team. Almost all military activity is performed with the assistance, coordination and awareness of other persons or other units. Many military personnel serve as team leaders where they have analyzed situations and options, made appropriate decisions, given directions, followed through with a viable plan, and accepted responsibility for the outcome.

3.Ability to Get Along with and Work with All Types of People: The veterans attracts all types of Technologists regardless of race, gender, economic status, age, religion, attitude, intelligence, or physical conditions. In the Service, military personnel have worked for and with people of all types of backgrounds, attitudes and characteristics. This experience has prepared veterans and their families to work with all types of people on a continuing basis.

4.Ability to Work Under Pressure and to Meet Deadlines: One definite characteristic of the military service is that service members must perform. They must do their job, do it right the first time and do it in a timely manner. They are continuously setting priorities, meeting schedules and accomplishing their missions. Pressure and stress are built into this, but service members are taught how to deal with all these factors in a positive and effective manner. They enjoy working together

5.Ability to Give and Follow Directions: People in the military know how to work under supervision and can relate and respond favorably to

others. They understand accountability for their actions and for their subordinates' actions. They also understand and use discipline in their lives and when dealing with others. They have learned to respect and accept legitimate authority.

6. Drug Free: With an honorable discharge, service members are certified drug free and are able to create a drug free nation by creating Creative Industrial Arts Exhibition Demonstration Centers in every county. Kenyans will view this as a distinct advantage.

7. Systematic Planning and Organization: Most military operations require thorough planning and workload management. Carefully considered objectives, strengths and limitations of other people, resources, time schedules, supplies, logistics, and various other factors are always considered. Organization, evaluation and adjustment are continuously being assessed. The ability to participate, direct or establish systematic planning is highly valued in business.

8. Change Environment: Military has ability to change any environment to be conducive for habitation. They can wasteland land into creative recreational parks.

9. Emphasis on Safety: Military safety training is among the best in the world. Service members understand the considerable cost in lives, property and objectives when safety is ignored. Both the control and the emphasis on safety are valued in the civilian work force.

10. Familiarity with Records and Personnel Administration: Service members are familiar with the necessity of keeping accurate records and completing all paperwork. There is always the requirement for accountability. Service members are also familiar with all facets of personnel administration.

11. Ability to Conform to Rules and Structure: In any large organization, and especially the military, there must be rules and structure to avoid chaos and internal breakdown. Individuals in the service have learned and followed rules every day in their working environment. While in this environment, they have also learned loyalty to their units and their leaders. Companies always value employees who will be "company players" and team members that follow "the rules" of the organization.

12. Flexibility and Adaptability: All individuals in the service have learned to be flexible and adaptable to meet the constantly changing

needs of any situation and mission. Last minute changes are not uncommon in any military or civilian working environment. Also based on their military background, former soldiers are able to adapt quickly to physical and safety demands.

13. Self-Direction: Many service members understand difficult and often complex issues and solve these issues or problems on the spot without step-by-step guidance from above.

14. Educated: All military soldiers have at least a K.S.C.E. and the majority of them have high school diplomas. Many have attended college to further their education.

15. Initiative: Many military personnel have the ability to originate a plan of action or task to answer and solve many unusual problems regarding supplies, logistics, resources and transportation.

16. Work Habits: People in the military stay and finish their projects and are known and are recognized for completing their missions in a timely fashion and in an effective, efficient manner. These work habits are a definite result of social maturity, integrity, determination and self-confidence that they have learned, earned and experienced in their military service. Their military background has instilled pride, enthusiasm and perseverance for their work. This constitutes their eligibility and recognition for promotion.

17. Standards of Quality and Commitment to Excellence: Service personnel are continually striving to attain and surpass their standards of quality for themselves and their units. These standards of quality are meeting their unit's mission, training standards, physical requirements and educational goals. There is a commitment to excellence in all of these fields.

18. Global Outlook: Many people in the military have been stationed and served their country in various locations around the world. This residency and international experience have broadened their outlooks in regards to customs, economies, languages and cultures of other countries.

19. Client and Service-Oriented: Many military personnel are in the service industry. Their jobs are to facilitate, explain and expedite their patrons and clients needs, wants and actions, such as administrative, medical, dental, postal, financial and recreational.

20. Concerned About the Community and Family

Environment: Service personnel have a vested interest in their areas where they reside. Many are committed to making their locations a better place to live. They are dedicated to the quality of life for their family members and their fellow residents. They participate and volunteer in youth sports, scouting activities, family and unit outings, area clean-up days, seasonal and unit parties and gatherings, and developmental programs. They are able to make Industrial Arts Exhibition Demonstration and Recreational Centers within our 47 counties

21. Specialized Advanced Training: All service personnel receive advanced training in their fields. Their career fields designate a specialized focus and skill building for their individual jobs. Advanced training and cross-referenced training can be in the computerized, financial, medical, engineering, administrative, personnel, technical, mechanical, and security fields. This training can be completed in the classroom, in the office, on the location, in the laboratory, or on the job.

22. Charging and discharging skills: Many young people admire military on performing art drills parade. The military are well charged with creativity skills and are able to discharge these skills to the apprentices throughout the country as they enjoy their retirement years.

Biblical Call for Technology innovations Exodus 35: 30-35

30 And Moses said unto the children of Israel, See, the LORD hath called by name Bezaleel the son of Uri, the son of Hur, of the tribe of Judah;

31 And he hath filled him with the spirit of God, in wisdom, in understanding, and in knowledge, and in all manner of workmanship;

32 And to devise curious works, to work in gold, and in silver, and in brass,

33 And in the cutting of stones, to set *them*, and in carving of wood, to make any manner of cunning work. 34 And he hath put in his heart that he may teach, both *he*, and *Aholiab*, the son of *Ahisamach*, of the tribe of *Dan*.

35 Them hath he filled with wisdom of heart, to work all manner of work, of the engraver, and of the cunning workman, and of the embroiderer, in blue, and in purple, in scarlet, and in fine linen, and of the weaver, *even* of them that do any work, and of those that devise cunning work.

Church

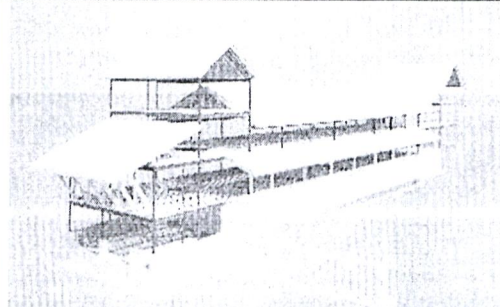
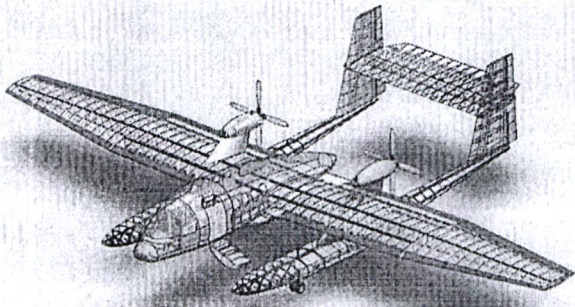
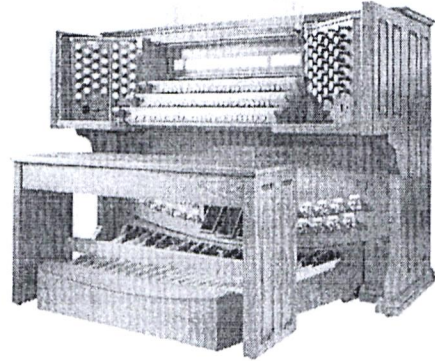
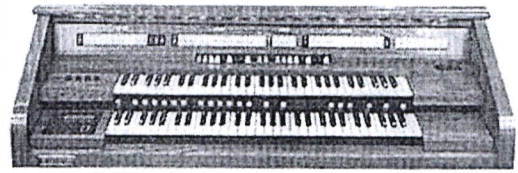

Social

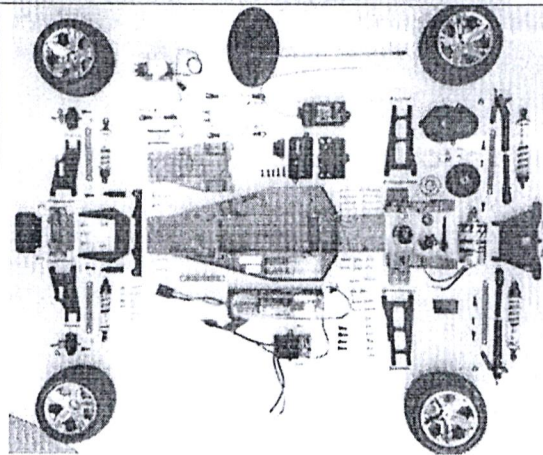
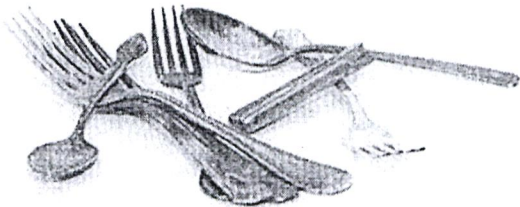

1. Profile /Objective

The association through their activities will try to minimize the effects of:

Alcoholism, Drug abuse and trafficking, Prostitution, Idleness among stranded youth and thus reducing HIV/AIDS&STDs

Our strategy is geared into establishing as many creative model Engineering clubs in all 47 counties in order to engage the youth into creative, enjoyable productive activities, which will intern create self employment and talents/careers development. Thereby reducing the unemployment stigma.

Young people will start realising their goals and mission in live, as they start giving services to their fellow men and women. They will enjoy work as they become part of it. The following work ethic creed will start guiding them throughout their life.

WORK ETHIC

- ❖ Work is essential to human existence. A worker produces goods or performs services that necessary to a fellow person or society.
- ❖ Work is privilege. It is a vehicle through which each person finds his or her mission in life.
- ❖ Work provides human relationship whereby one person helps another to reach a state of effective citizenship and wholesome living.
- ❖ Work recognizes that unemployment-underemployment- idleness or separation from meaningful work, is not conducive to human condition.
- ❖ Work is the foundation of human wealth; economic wealth, spiritual, moral and cultural wealth.
- ❖ Work involves the individual in activities that are essential to each person consistence to the needs of society.
- ❖ Work provides self-fulfillment so that each person can find meaning and purpose, ideals and values, and happiness in being part of society.
- ❖ Work produces recognition of a human integrity in relation to society.

Work oriented career education and manpower development and training are designed to reach the individual continuously throughout his or her life span. The pyramiding of in school and on-the-job employment training and experiences develops the capability

in the individual to deal at his or her level with the life problems, with environmental problems, and with social problems. Hence the level of poverty will start coming down.

PROJECTS

Bellow here are; some of many project which stimulates youth in learning and training in new innovative skills which are enjoyable, productive and fulfilling in their lives.

SKILLS TRAINING FOR EMPLOYMENT (S.T.E)

The Retired Defense Forces Technologists has the capacity to Create and maintain a healthy and respectful workplace requirement for everyone working together. They are able to maintain a well-balanced discipline for all. Watch your way through a series of short courses that will help you determine what discrimination and harassment in the workplace looks like, what to do if you experience it, and how to prevent it from happening in the first place. This course helps owner managers specifically navigate through tough topics and help maintain a respectful workplace

Why is the work oriented training path important?

- In the context of the diversification of learning paths for students, the **Work-Oriented Training** Path enables young people with learning difficulties to pursue their studies through adapted instruction in different contexts, **and** to obtain certification through qualifying **training** which prepares them for the job market.

How does the skills training for Employment Program work?

- The Skills **Training** for Employment (STE) **program** meets the needs of vulnerable **and** under-represented groups by providing skills **training and** employment supports to participants to help them obtain sustainable employment.

Why are orientation and training programs so important?

- Orientation and training programs are important components in the processes of developing a committed and flexible high-potential workforce and socializing new employees

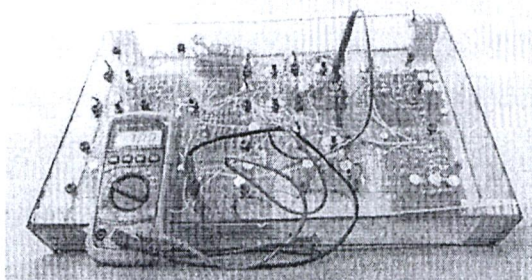

CREATIVITY IS THE MOTHER OF INOVATIONS AND INVENTIONS

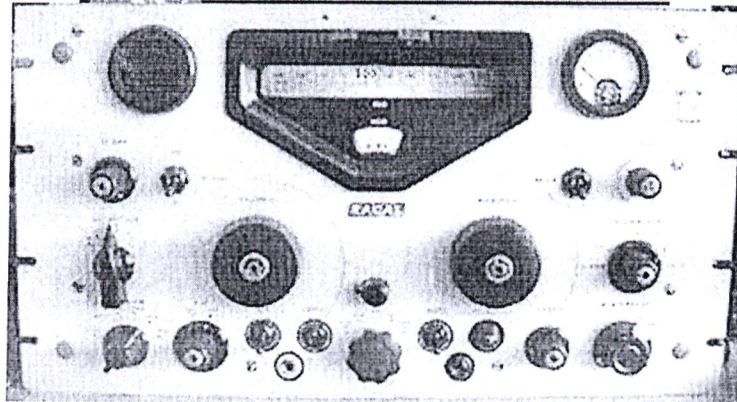
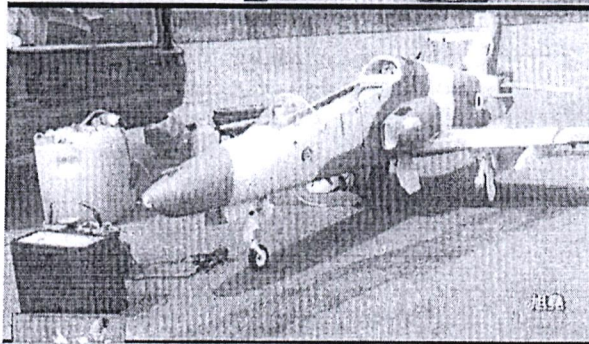
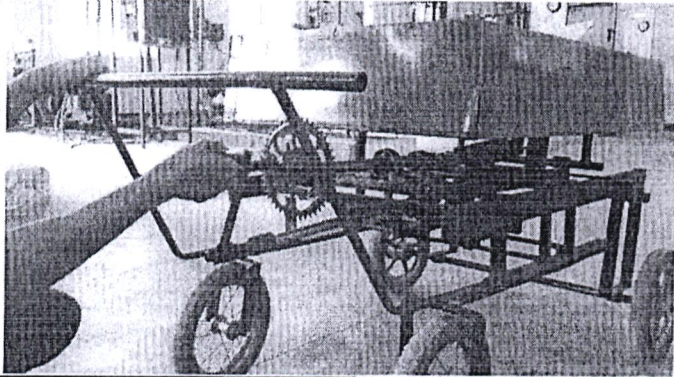
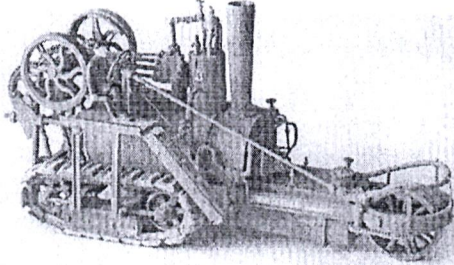

Creative Industrial Arts will offer short term work oriented courses in the many key areas of Technology and Business Development to apprentices to prepare them to enter the world of work job market

Design and Construction of Audio Amplifiers Ideal for small gathering.

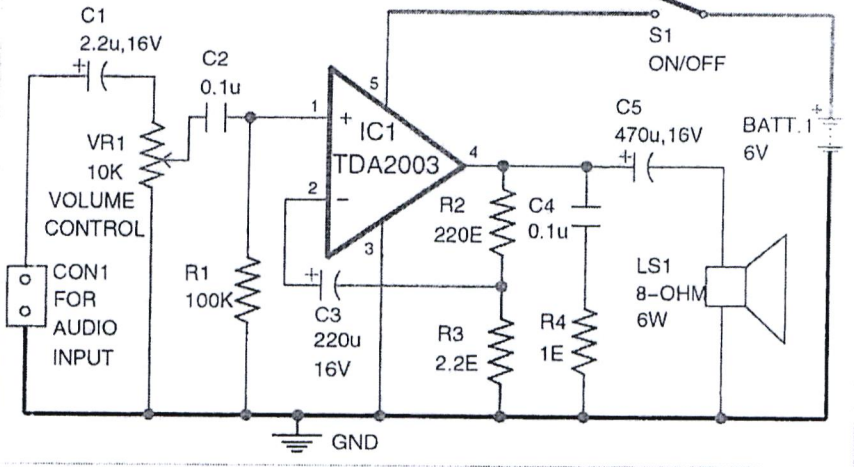

✓ **Design and Construction of low power supply unit.**

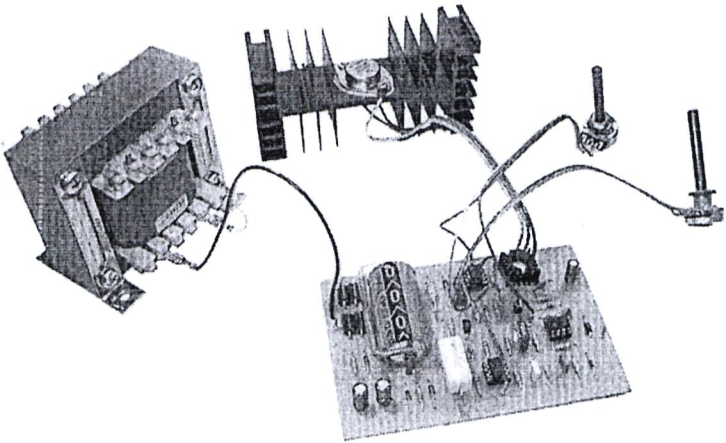

**Do it yourself
Creative Metal
Fabrications**

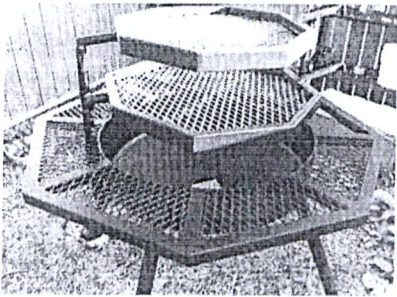



It is well understood from historical background of our country that: Service men has continued to retire from active service to civilian life. With no employment to sustain the life after retirement.

The veterans has continued to suffer the loneliness of lack of life rejuvenating activities that are enjoyable and fulfilling in the new civilian life. There many family breakdown leading to some committing suicide

CREATIVE THINKING

Creative thinking is the **ability to consider something in a new way**. It might be a new approach to a problem, a resolution to a conflict between employees, or a new result from a data set. Employers in all industries want employees who can think creatively and bring new perspectives to the workplace.

When you think creatively, you may find it easier to apply your imagination to everyday scenarios. This can help you come up with unique solutions to the challenges you may face at work. Creative minds **play with information** instead of just storing it. Instead of simply accepting ideas, they question them, build on them and apply them to their lives.

Creative thinking : Is a skill which lets you consider things from a fresh perspective and different angles. It's an inventive thought process which results in surprising conclusions and new ways of doing things. Creative thinking can be aided by brainstorming or lateral thinking to generate ideas. Examples of Creative Thinking Skills. How does a creative person work on a project? When **working** on a project, **creative people** tend to exhibit determination and doggedness. They will work for hours on something, often staying up late into the night until they are satisfied **with** their work.

MILLITARY GROUNDED EQUIPMENT

These are some of military grounded equipment which can be recycled and modified to be used in country's Technology and Business development, using the retired men and women. These activities will help the retired to cope with stress in civilian life

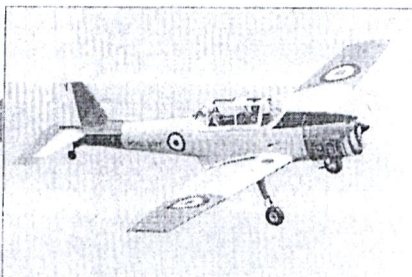

ADVERT

are not sunroofed them to deliver first, to engage in

agriculture, higher learning institutions electricity connectivity, markets and stadia as some of the development projects initiated in the region that backed the President in the last three elections.

President Kenyatta was on a mission to recapture his lost support and for him, his scorecard was his primary weapon.

"I took up the role of doing what can help Kenyans. Despite my tribulations, there is no President that has delivered more than me," he said. Along the Tagwa Road snaking through Mt Kenya Forest in Sa-

heavily armed police officers had been deployed to not only conduct security checks but also keep out uninvited guests amid intelligence reports that hecklers had been mobilised to sabotage it.

At the luxurious Sagana Lodge, hundreds of caterers had been deployed with the mission to keep the delegates refreshed and a battery of local benga and gospel musicians kept the crowd entertained. As for the crowd, the much touted Red Army was highly visible with the mobilised delegates donning Jubilee Party colours.

leading up to the Sagana State Lodge. PHOTO | PSCU

Kenyatta



REPUBLIC OF KENYA

**THE NATIONAL ASSEMBLY
TWELFTH PARLIAMENT (SIXTH SESSION)
DEPARTMENTAL COMMITTEE ON LABOUR AND SOCIAL WELFARE AND THAT ON
DEFENCE AND FOREIGN RELATIONS**

In the Matter of Article 118 (1)(b) of the Constitution and National Assembly Standing Order 127(3) and
In the Matter of consideration by the National Assembly of -

- 1) The Persons With Disabilities Bill, 2021 (National Assembly Bill No. 61 of 2021); and
- 2) The Military Veterans Bill, 2022 (National Assembly Bill No. 4 of 2022)

PUBLIC PARTICIPATION (SUBMISSION OF MEMORANDA)

Article 118(1)(b) of the Constitution provides that, "Parliament shall facilitate public participation and involvement in the legislative and other business of Parliament and its Committees". National Assembly Standing Order (S.O.) 127(3) provides that "the Departmental Committee to which a Bill is committed shall facilitate public participation and take into account the views and recommendations of the public when the Committee makes its report to the House".

The Persons With Disabilities Bill (National Assembly Bill No. 61 of 2021), sponsored by the Leader of the Majority Party, was read a First Time on Tuesday, 22nd February 2022 and thereafter committed to the Departmental Committee on Labour and Social Welfare for consideration and reporting to the House. The Bill seeks to give effect to Article 54 of the Constitution to restructure the National Council for Persons with Disabilities and to provide for its functions and powers to provide for the institutional framework for protecting, promoting and monitoring the rights of persons with disabilities; and for connected purposes.

The Military Veterans Bill (National Assembly Bill No. 4 of 2022), sponsored by the Leader of the Majority Party was read a First Time on Tuesday, 22nd February 2022 and thereafter committed to the Departmental Committee on Defence and Foreign Relations for consideration and reporting to the House. The Bill seeks to establish a regulatory and institutional framework for the management of military veterans' affairs, for the provisions of benefits to military veterans and military veterans' dependants; to establish the dependants' Education Fund; to establish the Defence Forces Retirement Home and for connected purposes.

Now therefore, in compliance with Article 118 (1) (b) of the Constitution and National Assembly Standing Order 127(3), the Committees hereby invite the general public and stakeholders to submit memoranda on the two Bills. Copies of the Bills are available at the National Assembly Table Office or on www.parliament.go.ke/the-national-assembly/house-business/bills.

The memoranda may be submitted to the Clerk of the National Assembly, P.O. Box 41842-00100, Nairobi; hand-delivered to the Office of the Clerk of the National Assembly, Main Parliament Buildings, Nairobi; or emailed to clerk@parliament.go.ke; to be received on or before Friday, 11th March, 2022.

MICHAEL R. SIALAL CRS
CLERK OF THE NATIONAL ASSEMBLY

24th February 2022

"For the Welfare of Society and the just Government of the People"

ADOPTION LIST

REPUBLIC OF KENYA







KENYA NATIONAL ASSEMBLY

DEPARTMENTAL COMMITTEE ON DEFENCE AND FOREIGN RELATIONS
Adoption Schedule

REPORT OF THE DEPARTMENTAL COMMITTEE ON DEFENCE AND FOREIGN RELATIONS ON THE CONSIDERATION OF THE MILITARY VETERANS BILL, 2022 (NATIONAL ASSEMBLY BILL NO. 4 OF 2022)

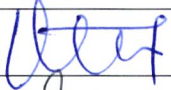
We, the undersigned Members of the Departmental Committee on Defence & Foreign Relations, today 12th April, 2022 do hereby affix our signatures to this REPORT ON THE CONSIDERATION OF THE MILITARY VETERANS BILL, 2022 to affirm our approval and confirm its accuracy, validity and authenticity:-

NO.	NAME	SIGNATURE
1.	The Hon. Richard Tongi, MP - (Chairperson)	
2.	The Hon. Elijah Memusi Kanchory, MP (Vice-Chairperson)	
3.	The Hon. (Dr.) Adan Keynan Wehliye, CBS, MP	
4.	The Hon. Col (Rtd.) Gideon S. Konchela, EGH, OGW, 'psc' (UK), M.P	
5.	The Hon. Yusuf Hassan Abdi, MP	
6.	The Hon. Charles Kilonzo, MP	
7.	The Hon. Col (Rtd.) Dido Ali Raso, MBS, MP	
8.	The Hon. Richard Maore Maoka, CBS, MP	
9.	The Hon. Martha Wangari Wanjira, MP	
10.	The Hon. Stephen Mutinda Mule, MP	

11.	The Hon. Major (Rtd.) Bashir Sheikh Abdullah, MP	
12.	The Hon. (Dr.) Lilian Gogo, MP	
13.	The Hon. (Dr.) Irene Muthoni Kasalu, MP	
14.	The Hon. Moses Nguchine Kirima, MP	
15.	The Hon. Vincent Kipkurui Tuwei, MP	
16.	The Hon. Ernest Ogesi Kivai, MP	
17.	The Hon. Caleb Amisi, MP	
18.	The Hon. Asha Hussein Mohamed, MP	
19.	The Hon. Zachary Kwenya Thuku, MP	